

» FTA54+ Basic RS485 Modbus

Outdoor sensor for relative humidity and temperature

thermokon[®]
HOME OF SENSOR TECHNOLOGY

Datasheet

Subject to technical alteration
Issue date: 01.03.2021 • A112



» APPLICATION

Sensor for measuring humidity and temperature in outdoor areas. In delivery condition, the sensor is designed for measuring temperature and relative humidity. Alternatively the output can be set to absolute humidity, enthalpy or dew point. A mounting base for mounting on a level surface and fixing material are included in delivery.

» TYPES AVAILABLE

Outdoor humidity sensor temperature + humidity – active BUS

FTA54+ Basic RS485 Modbus

» SECURITY ADVICE – CAUTION



The installation and assembly of electrical equipment should only be performed by authorized personnel.

The product should only be used for the intended application. Unauthorised modifications are prohibited! The product must not be used in relation with any equipment that in case of a failure may threaten, directly or indirectly, human health or life or result in danger to human beings, animals or assets. Ensure all power is disconnected before installing. Do not connect to live/operating equipment.

Please comply with

- Local laws, health & safety regulations, technical standards and regulations
- Condition of the device at the time of installation, to ensure safe installation
- This data sheet and installation manual

» NOTES ON DISPOSAL



As a component of a large-scale fixed installation, Thermokon products are intended to be used permanently as part of a building or a structure at a pre-defined and dedicated location, hence the Waste Electrical and Electronic Act (WEEE) is not applicable. However, most of the products may contain valuable materials that should be recycled and not disposed of as domestic waste. Please note the relevant regulations for local disposal.

» BUILD-UP OF SELF-HEATING BY ELECTRICAL DISSIPATIVE POWER

Temperature sensors with electronic components always have a dissipative power, which affects the temperature measurement of the ambient air. The dissipation in active temperature sensors shows a linear increase with rising operating voltage. This dissipative power has to be considered when measuring temperature. In case of a fixed operating voltage ($\pm 0,2$ V) this is normally done by adding or reducing a constant offset value. As Thermokon transducers work with a variable operating voltage, only one operating voltage can be taken into consideration, for reasons of production engineering. Transducers 0..10 V / 4..20 mA have a standard setting at an operating voltage of 24 V =. That means, that at this voltage, the expected measuring error of the output signal will be the least. For other operating voltages, the offset error will be increased by a changing power loss of the sensor electronics. If a re-calibration should become necessary later directly on the sensor, this can be done by means of a trimming potentiometer on the sensor board.

Remark: Occurring draft leads to a better carrying-off of dissipative power at the sensor. Thus temporally limited fluctuations might occur upon temperature measurement.

» APPLICATION NOTICE FOR HUMIDITY SENSORS

Refrain from touching the sensitive humidity sensor/element. Touching the sensitive surface will void warranty.

For standard environmental conditions re-calibration is recommended once a year to maintain the specified accuracy. When exposed to high ambient temperature and/or high levels of humidity or presence of aggressive gases (i.e. chlorine, ozone, ammonia) the sensor element may be affected and re-calibration may be required sooner than specified. Re-calibration and deterioration of the humidity sensor due to environmental conditions are not subject of the general warranty.

» PRODUCT TESTING AND CERTIFICATION



Declaration of conformity

The declaration of conformity of the products can be found on our website <https://www.thermokon.de/>.

» USE ENCLOSURE WITH UV AND WEATHER RESISTANCE

After some time, outdoor mounted plastics can lose their color and quality. Therefore, all USE housings are made of special white polycarbonate (PC). The light-stable colorants and additives are used to achieve optimum protection of the polymer while maintaining color stability. The titanium dioxide used is specially developed for polycarbonate and offers excellent UV protection through the reflection of the entire light spectrum including the UV component by 340 nm. This effectively counteracts the otherwise occurring photochemical polymer degradation. The colors stay full for a long time without fading. The material is also resistant to cold and frost.

» APPLICATION NOTICE

After a certain time, dirt in the air can collect on the filter and then adversely affect the operation of the sensor. Under normal ambient condition an annual maintenance is recommended. Rinse the filter after cleaning with distilled water and dry it using clean oil-free air or nitrogen. Extremely contaminated filters should be replaced. At extreme ambient conditions, e.g. corrosive gases, the humidity sensor may have to be changed.

» **TECHNICAL DATA**

Measuring values	temperature, humidity
Network technology	RS485 Modbus, RTU or ASCII, half-duplex, baud rate 9.600, 19.200, 38.400 or 57.600, parity: non (2 stopbits), even or odd (1 stopbit)
Power supply	15..24 V = (±10%) (or 24 V ~ (±10%))* SELV
Power consumption	max. 0,7 W (24 V =) 1,8 VA (24 V ~)
Measuring range temp	-20..+80 °C
Measuring range humidity	0..100% rH non-condensing
Accuracy temperature	±0,3 K (typ. at 21 °C)
Accuracy humidity	±2% between 10..90% rH (typ. at 21 °C)
Enclosure	enclosure USE-M, PC, pure white, UV resistant
Protection	IP65 according to EN 60529
Cable entry	Flextherm M20, for wire Ø=4,5..9 mm, removable
Connection electrical	removable plug-in terminal, max. 2,5 mm ²
Pipe	PC, pure white
Filter	stainless steel wire mesh
Ambient condition	-20..+70 °C, short term condensation

***Power supply**

When several BUS devices are supplied by one 24 V AC voltage supply, it is to be ensured that all “positive” operating voltage input terminals (+) of the field devices are connected with each other and all “negative” operating voltage input terminals (-) (=reference potential) are connected together (in-phase connection of field devices).

In case of reversed polarity at one field device, a supply voltage short-circuit would be caused by that device. The consequential short-circuit current flowing through this field may cause damage to it.

Therefore, pay attention to correct wiring.

» **MOUNTING ADVICES**

In case of outdoor installation avoid direct rain and sun contact. Probably use sun respectively rain protection. Cable entry from bottom or side. For side cable routing set loop so that precipitation can drain defined. Observe permissible ambient condition.

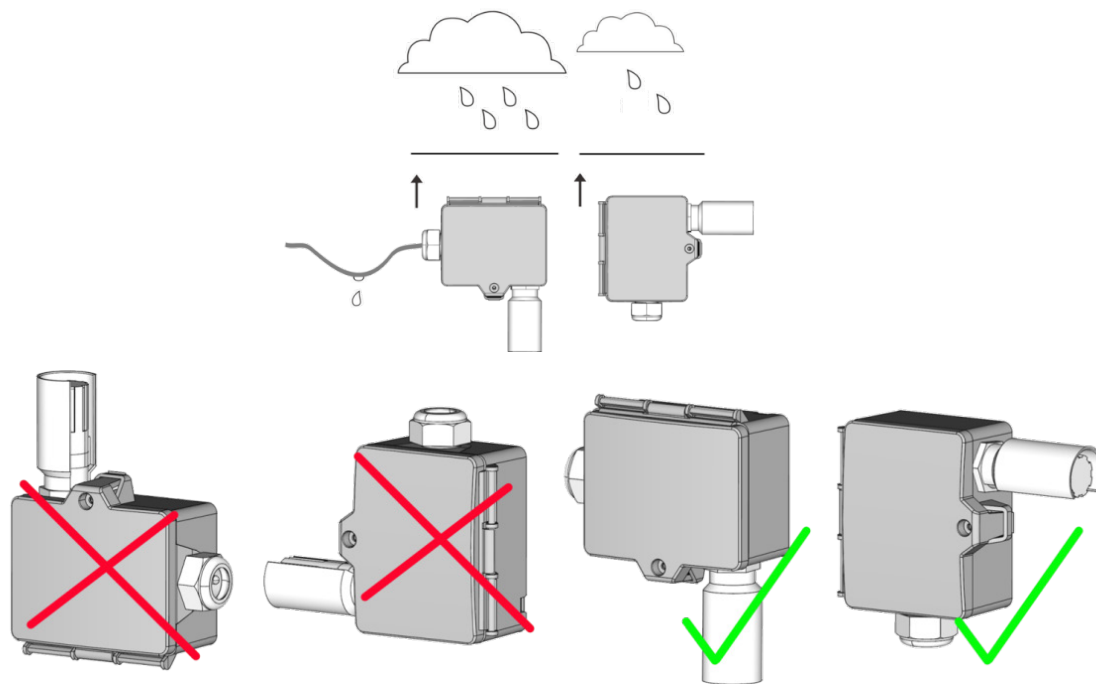

» CONNECTION PLAN AND CONFIGURATION

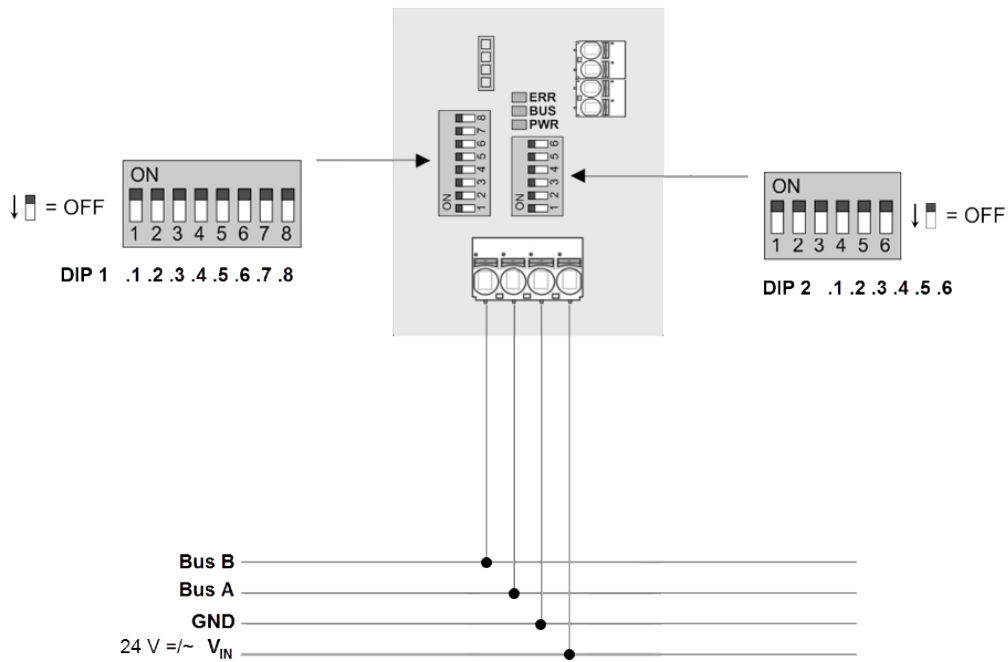

LED	Description
ERR	Indicator for error notification
BUS	Indicator for RS485 traffic
PWR	Power supply

Device Address (binary coded)

DIP 1.1	DIP 1.2	DIP 1.3	DIP 1.4	DIP 1.5	DIP 1.6	DIP 1.7	DIP 1.8	Address
2 ⁰	2 ¹	2 ²	2 ³	2 ⁴	2 ⁵	2 ⁶	2 ⁷	
ON	OFF	OFF	OFF	OFF	OFF	OFF	OFF	1
OFF	ON	OFF	OFF	OFF	OFF	OFF	OFF	2
ON	ON	OFF	OFF	OFF	OFF	OFF	OFF	3
...								
ON	ON	ON	ON	ON	ON	ON	ON	247

Modbus interface settings

DIP 2.1	Mode	DIP 2.2	DIP 2.3	Baud	DIP 2.4	DIP 2.5	Parity	DIP 2.6	Register
OFF	RTU	OFF	OFF	9.600	ON	OFF	even	OFF	UNI
ON	ASCII	ON	OFF	19.200	OFF	ON	odd	ON	USE
		OFF	ON	38.400	OFF	OFF	none (2 Stopbits)		
		ON	ON	57.600	ON	ON	none (1 Stopbit)		

Factory default

Device address: 1 | RTU | Baud rate: 9.600 | Parity: even | Register addressing: USE

Register compatibility to USE (Valid from firmware version 1.4, Jan. 2020)

Via dipswitch 2.6 it is possible to change between the previous register addressing of the UNI-Modbus board to a USE compatible register assignment. The function of the device does not change.

When using ASCII mode, parity must be set to EVEN or ODD. „No Parity“ (no) is not available in ASCII mode.

» RS485 MODBUS REGISTER

Variant 1 (UNI-Modbus) DIP 2.6 = OFF

Data address	Function code	Description	Type
0 _{dec} 0x0000 _{hex}	3 (R)	Firmware z.B.: 0x1000 = Version 1.0.0.0	SIGNED 16 Bit
1 _{dec} 0x0001 _{hex}	4 (R/W)	Device Location	SIGNED 16 Bit
585 _{dec} 0x0249 _{hex}	3 (R)	Relative humidity [1/10] %	SIGNED 16 Bit
587 _{dec} 0x024B _{hex}	3 (R)	Temperature [1/100] °C	SIGNED 16 Bit
588 _{dec} 0x024C _{hex}	3 (R)	Temperature [1/100] °F	SIGNED 16 Bit
5 _{dec} 0x0005 _{hex}	4 (R/W)	Offset temperature [1/100] K	SIGNED 16 Bit
6 _{dec} 0x0006 _{hex}	4 (R/W)	Offset rel. humidity [1/100] %	SIGNED 16 Bit

Variant 2 (USE-Modbus) DIP 2.6 = ON

Data address	Function code	Description	Type
503 _{dec} 0x01F7 _{hex}	3 (R)	Firmware version i.e.: 0x1300 = Version 1.3.0.0	SIGNED 16 Bit
400 _{dec} 0x0190 _{hex}	4 (R/W)	Unit system 1 = SI 2 = Imperial	SIGNED 16 Bit
0 _{dec} 0x0000 _{hex}	3 (R)	Temperature [1/10] °C/°F	SIGNED 16 Bit
1 _{dec} 0x0001 _{hex}	3 (R)	Relative humidity [1/10] %rH	SIGNED 16 Bit
100 _{dec} 0x0100 _{hex}	4 (R/W)	Offset temperature [1/10] K	SIGNED 16 Bit
101 _{dec} 0x0101 _{hex}	4 (R/W)	Offset rel. humidity [1/10] %rH	SIGNED 16 Bit

» DIMENSIONS (MM)

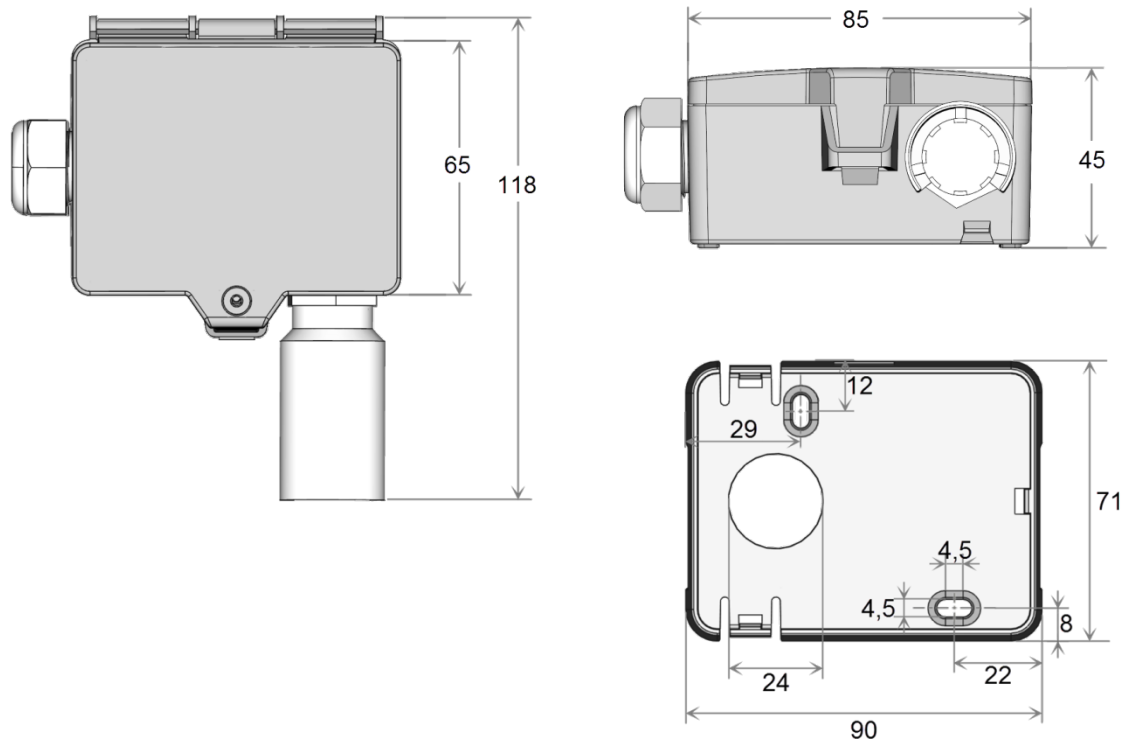

» ACCESSORIES (INCLUDED IN DELIVERY)

Rain protection

Item No. 670715

Mounting base

Item No. 631228

Mounting kit universal

Item No. 698511

• Cover screw + screw cover • 2 Rawlplugs • 2 Screws (countersunk head) • 2 Screws (rounded head)

» ACCESSORIES (OPTIONAL)

Cable entry M25 USE white, sealing insert 4x Ø=7 mm (4 pcs)

Item No. 641364

Filter stainless steel, wire mesh

Item No. 231169

Sealing insert M20 USE white, 2x Ø=7 mm (for 2 wire; PU 10 pieces)

Item No. 641333