

Start-up instructions

Thyristor controller Type: Tyco-3Ph, Tyco-3Ph/SP Three phase controller W3C

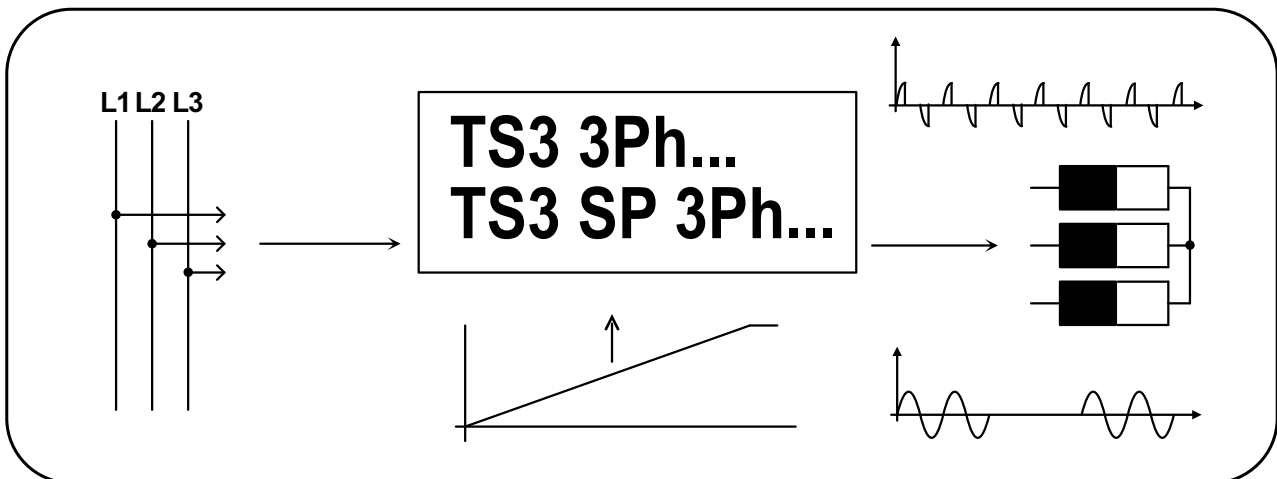

Content

	Page
1. Important safety instructions.....	2
2. General instructions.....	2
3. Technical explanations on thyristor controllers.....	3
3.1 Explanation phase angle control Ph.....	4
3.2 Explanation multicycle control (burst-firing control).....	5
4. Installation of the thyristor controller TS3 3Ph, TS3 SP 3Ph.....	6
5. EMC-equitable assembly.....	6
6. Operation.....	8
7. Meaning of the clamp connections.....	9
8. Meaning of the LEDs and potentiometer.....	10
9. Description of the control inputs.....	13
10. Basic circuit.....	14
10.1 Basic circuit for TS3 3Ph... or TS3 SP 3Ph... with controlclamps.....	15
11. Survey of the individual types.....	16
12. Technical data.....	17
13. Options and equipment.....	18

1. Important safety instructions

This manual contains instructions, which have to be observed for your personal safety and for the prevention of material damage. The instructions about your personal safety are highlighted with a warning triangle labelled with three exclamation marks, hints about material damages are listed with a warning triangle and one exclamation mark.



Danger-symbol

Personal injury **may** occur, if appropriate safety precautions are not taken.



Caution-symbol

Material damages may occur, if appropriate safety precautions are not taken into account.



Disposal regulations

The devices contain electrical components and must not be disposed together with household garbage. The devices for disposal have to be recycled according to local and currently valid regulations for electronic waste.

Qualified personnel

The corresponding device/system may only be set up and operated in conjunction with this documentation. Commissioning and operation of the device/system may only be performed by **qualified personnel**. Qualified personnel within the meaning of the safety instructions in this documentation are persons with the authority to put electric circuits into operation, provide ground connections and label them according to current safety regulations.

The device should only be used in applications described in this document. The reliable and proper use of the product depends on appropriate transport, storage, installation and careful commissioning.

2. General instructions

Use of the document

This instruction should demonstrate the technical application possibilities of the thyristor controller to the engineer in charge.

Target group

The document should assist the user during commissioning. It also helps in case of service and maintenance work. It supports the planner and project engineer with the conception of new plants.

Necessary competence

Generic skills in the field of electrical engineering are necessary.

Validity

The present document is valid for the thyristor controller of the type TS3 3Ph, TS3 SP 3Ph. It contains the currently valid description of the unit. We reserve the right to attach new descriptions of the devices. This involves types and options with modified version status of the technical documents.

Standards and approvals

The thyristor controller of the type TS3 3Ph, TS3 SP 3Ph are based on the IEC/EN 60947-4-3 standard.

Disclaimer

It lies within the responsibility of the plant manufacturer of the technical equipment or machine to ensure the proper overall function. The producer can not guarantee all properties of the overall system or the machine.

3. Technical explanations on thyristor controllers

The thyristor controller is more and more used in sectors, in which bigger loads of ohm and inductive loads have to be regulated (i.e.: building of industrial furnaces, plastics processing, etc.).

Due to its modular, compact construction and its controlling by a continual control signal, these wattage regulators become a perfect device for industrial control of wattage input. The power element of the thyristor controller consists at the TS3 1Ph... of two, at the TS3 3Ph of six antiparallel connected thyristors, the isolated cooling system and the electronic regulation and watching.

Type description:

TS3 1Ph...	single phase controller, phase angle control
TS3 SP 1Ph...	single phase controller, multicycle control
TS3 3Ph...	three phase controller, phase angle control
TS3 SP 3Ph...	three phase controller, multicycle control

Auxiliary Voltage:

The devices are powered internal by the mains voltage. Optional can devices with different mains voltage be supplied with an external auxiliary voltage.

Construction:

The thyristor controller agrees with Low voltage directive: 2014/35/EU, EN60947-4-3 and EMC Directive: 2014/30/EU, EN60947-4-3 Kl.A.

The thyristor controller TS3 3Ph... is assembled modularly. It consists of two basic elements:

- power unit with heat sink and thyristor wiring
- control and monitoring unit with ignition electronics (diagnostic display, control output, etc.)
- optional can devices with different mains voltage be supplied by an external auxiliary voltage

3.1 Explanation phase angle control Ph

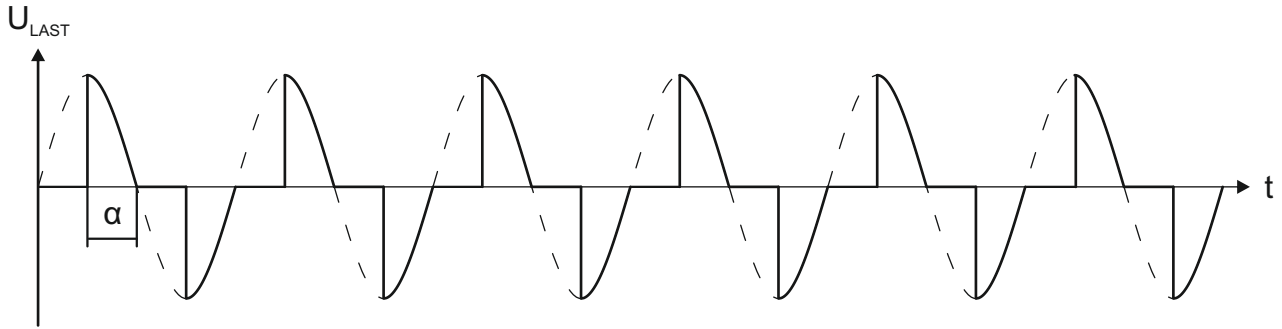

The phase angle control is an electrotechnical method to regulate the electrical power of loads with single phase current or three phase current. A typical use of this technology is dimming of light bulbs and various inductive and ohmic components. The effective value of the voltage as well as the electrical power consumption of the load can be changed by altering the switch-on moment. For many electrical engines with suitable construction (for example universal motors, asynchronous motors, fan motors or pump motors) a phase angle control can be used to control speed and torque. Due to the controllability of the positive and negative half-wave it is possible to adjust exactly the load voltage and to implement precise control applications. The variation of the phase angle α also allows the control of transformers for softstart- and control applications.

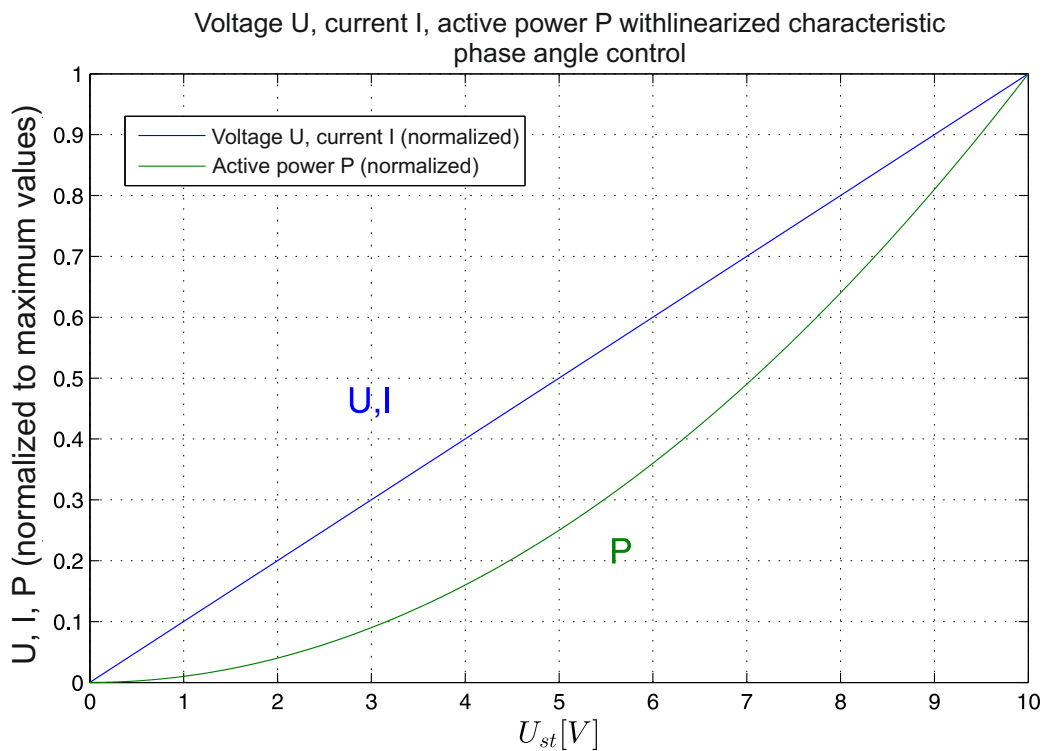

U_{\max}
 I_{\max}
 P_{\max}

$$P = U_{\max} \cdot I_{\max} \cdot \left(\frac{U_{st} [V]}{10V} \right)^2$$

$$U = U_{\max} \cdot \frac{U_{st} [V]}{10V}$$

$$I = I_{\max} \cdot \frac{U_{st} [V]}{10V}$$

3.1 Explanation multicycle control SP (burst-firing control)

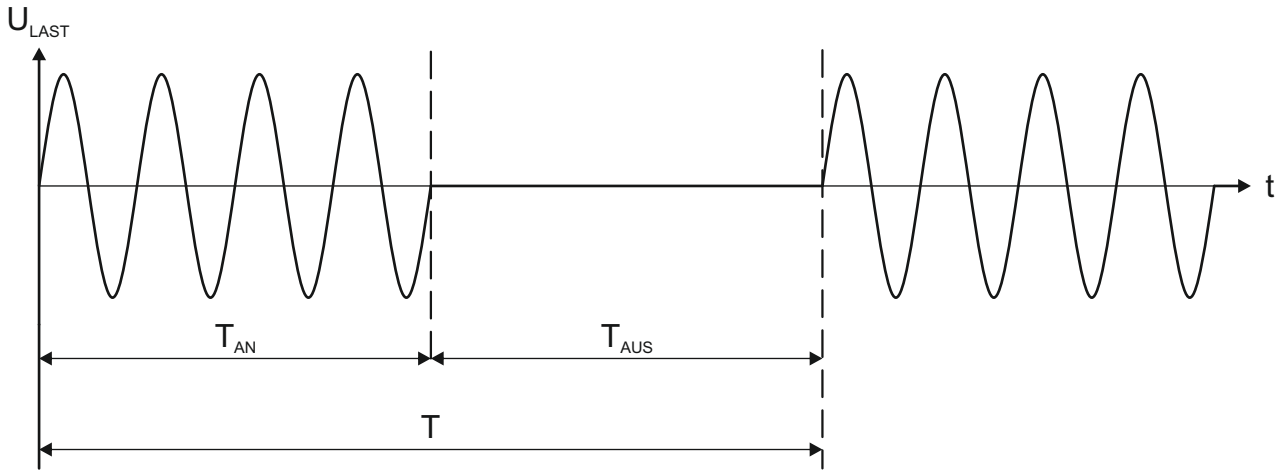

In this operating mode the thyristor controller ensures the targeted switching of individual full waves of the power supply. Depending on the control signal individual halfwaves (positive half-waves, negative half-waves) and wave packets can be switched, in which the switching point is always at the sinus zero crossing. The impulse(T_{AN})-pause(T_{AUS})-ratio controls the electrical power. This kind of operation mode reduces system perturbation. As basis for the switching intervals (impulse-pause-ratio) the devices normally operate with a time base T of one second (1s corresponds to 50 full-waves). Possible application areas are electric heatings, heat technology, and drying technology. Newer models offer combinations of phase angle control and multicycle control SP as well as different adjustment options in relating to the impulse (T_{AN})-pause(T_{AUS})-ratio.

For example:

A control signal of $U_{st} = 5V$ with a control range of 0 to 10V creates a impulse duration T_{AN} of 25 full-waves (500 ms) and a pause duration T_{AUS} of 25 full-waves (500ms).

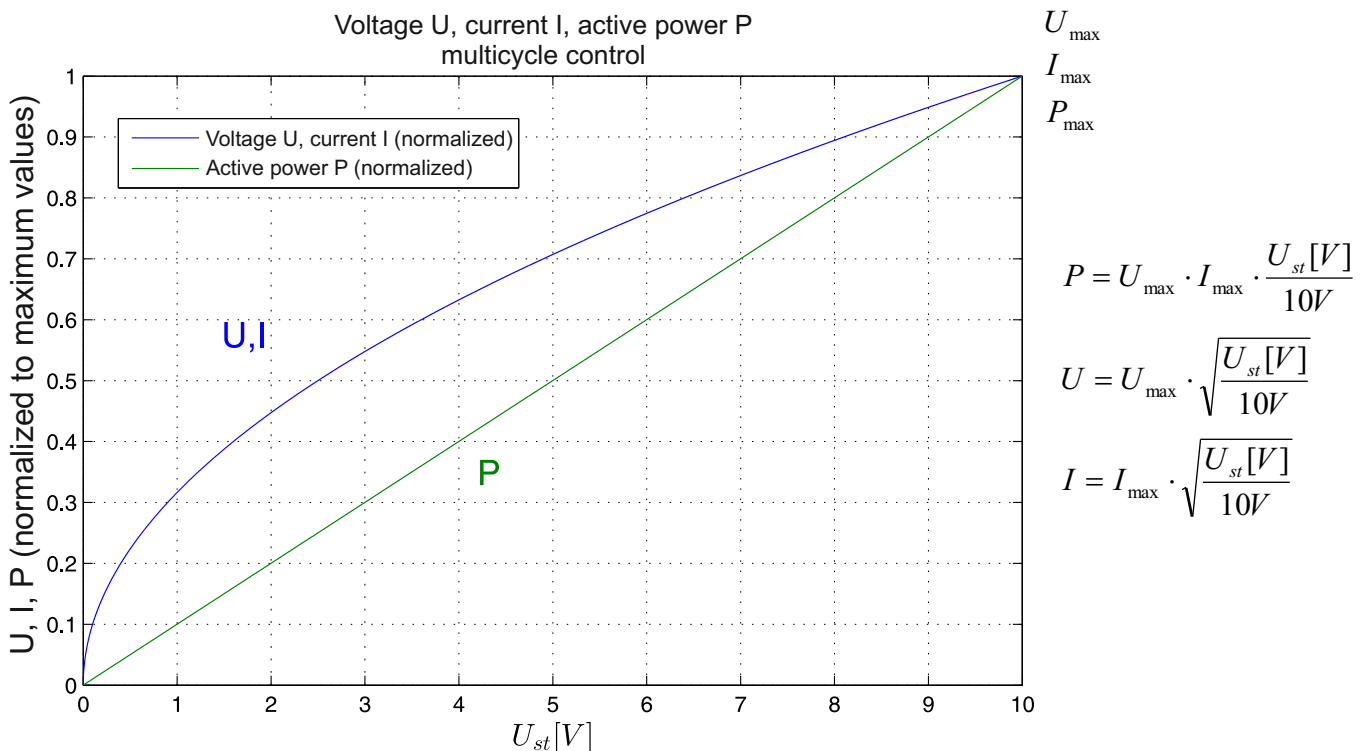

4. Installation of the thyristor controller TS3 3Ph, TS3 SP 3Ph

The thyristor controller (IP 40) should be mounted vertically in a housing. The upper and lower side of the heat sink have to be kept free to allow cooling air to circulate freely. The temperature may not cross 50 °C. Controllers must be mounted on a flat surface to ensure that cooling air is channelled to the heat sink. The thyristor configuration is indifferent to the order of the supply phase rotation.

Further conditions to the operating area:



- protection from dust and moisture
- protection from aggressive atmosphere
- free from vibrations

No other devices should be placed closer than 50 to 100mm to the device, in order to provide adequate cooling.

The housing design according to IP 54 (Option) can be mounted in places which are not protected from dust and humidity.

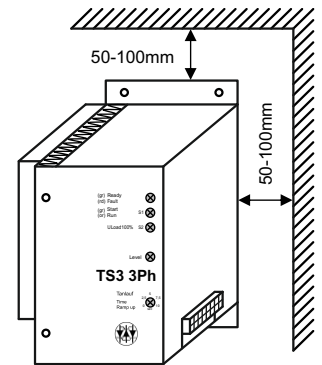

Wiring the device:



The mains connections L1, L2, L3 (N) have to be connected by using a disconnecting switch and usual fuses.

The connection for mains cable and the connections for controlling have to be laid in channels and protector tubes.

The electric installation always has to comply with the essential protection requirements of the European Low Voltage Directive 2014/35/EU and Electromagnetic compatibility Directive 2014/30/EU.

5. EMC-equitable assembly

According to EMC standards thyristor controllers are regarded as components, which do not fulfil any intended use by themselves. The devices constitute a functional unit of the entire plant. The control electronics of the thyristor controllers are implemented according to valid EMC standards.

The builder of the plant has to supply the plant with appropriate mains chokes and mains filters. These components can also be obtained from us. Thyristor controllers with multicycle control usually do not require any additional mains filter circuit.

It should be noted that the standards of the resource category A are not sufficient in a special industrial sector, for example if sensitive measuring channels are affected. In this case, the user has to apply equipment of class B.

The class A is the usual class of equipments, which is normally intended for the use in the industrial sector. The devices are connected to the industrial network via an assigned transformer. Power controllers of class B are required if they should be used in the area of industry and small-scale industry and if they should be connected to the public low-voltage system.

Use of mains chokes:

On the input side of the thyristor controllers, mains chokes reduce the current-dependent line reactions and effect an improvement of the performance factor. This reduces the current harmonics and improves the mains quality. The use of mains chokes is particularly recommended when connecting thyristor controllers with phase angle control to a grid-feeding point and when other electronic devices are attached to this network.

Use of mains filters:

Radio interference filters and mains filters (combination of radio interference filter and one mains choke) serve for protection against high-frequency disturbances, which are sent out via the power cable or the radiation of the power cable. The high-frequency disturbances should be limited to a mandatory or legal degree. Mains filters should possibly be mounted close to the thyristor controller and moreover it is necessary to ensure that the connecting cable between the thyristor controller and the mains filter is as short as possible.

CAUTION: The mounting surfaces of the thyristor controllers and the radio interference filters have to be free from paint and well conducting in the high-frequency range.

Furthermore, mains filters have leakage currents, which may become significantly larger than the nominal values in case of failure (phase failure, unbalanced load). To avoid dangerous voltages, the mains filters have to be grounded. As the leakage currents are high-frequent disturbances, the grounding measures have to be low-resistance and extensive.

With leakage currents, which exceed the value of 3,5mA, VDE 0160 or EN 60335 specify that either:

- the cross section of the protective conductor has to be $\geq 10\text{mm}^2$,
- the protective conductor has to be monitored on interruption or
- a second protective conductor has to be laid.

Shielding measures:

Shielding measures help to reduce the radiated interference energy. Electrical lines between thyristor controller and load can be laid shielded. Thereby the shield must not replace the PE line. Four-wire cables (three phases + PE), whose shield is double-sided and extensive laid on earth potential (PES), are recommended. The shield must not be applied over the connecting wires. Interruptions of the shielding e.g. in the case of clamps, contactors, mains chokes etc. have to be bridged with low-resistance and appropriate space considerations.

In practice this can be done for example by interrupting the shield close to the assembly and then connecting it extensively with the earth potential (PES, shield clamp). The free cables, which are not shielded, should not be longer than 100mm.

Grounding measures:

Grounding measures are absolutely necessary to fulfil legal provisions. They constitute a prerequisite for an efficient use of further measures such as filters and shielding. All conductive, metallic housing components have to be electroconductive connected with the earth potential. For the EMC-measure, the important factor is not the cable's crosssection, but its surface, since this is where high frequency current flows to earth. Once again, all grounding points have to be led directly, extensively and with low-resistance to the central grounding point (equipotential bonding bar, star-shaped grounding system). The contact points have to be free from paint and corrosion (use galvanized mounting plate and materials).

6. Operation



First, all the electrical connections have to be made according to the enclosed circuit diagrams: L1, L2, L3 (N), T1, T2, T3. The thyristor controllers have to be connected to the mains supply as per VDE regulations, so that they can be disconnected from the mains supply by means of corresponding separation devices (e.g. main switch, contactor, circuit breaker).

Cable laying:

The mains supply line, the consumer supply line and the control lines have to be led in separated cables.

To avoid disturbances, it is advisable to do the wiring of the electronic signal lines isolated from the power and/or contactor control lines and to twist the toward and return lines of the signal lines (see also point 5. EMC-equitable assembly).

Fuses:

The mains fusing depends on the recommended or used wire cross-section and has to be made according DIN 57100 part 430/VDE 0100 part 430/6.81.

General information:

Thyristor controller for phase angle (TS3 1Ph... and TS3 3Ph...) serve to control ohmic and inductive loads. The activation is standardly made via proportional signals (0...10V or 0...20mA). The phase angle or the input and output clock ratio with multicycle control (TS3 1Ph... and TS3 3Ph...) is constantly adjusted by the control electronics, to achieve an adequate proportionality between the activation of the thyristor controller and the output (T1, T2, T3).

Beside these already mentioned device series, TS3 1Ph... and TS3 3Ph..., we also have single-phase and three-phase versions, which cover the upper voltage range up to 2500A. These devices are also for short delivery.

General information on the PTC-thermistor:

PTC-temperature sensors according to DIN 44081 (triplet design DIN 44082) are used to protect electrical machines against thermal overload. According to the present DIN standard they are arbitrarily exchangeable among themselves. It is a range of types from 60 to 190°C available.

PTC-temperature sensors with different rated shut-off temperatures can also be connected in series. Thereby it is possible to get optimum use out of machine Components and winding parts with different limit temperatures and to protect them cost-effectively.

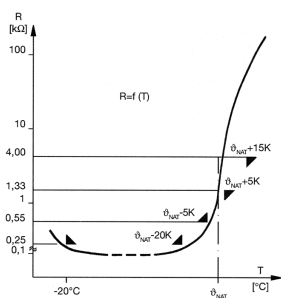

Technical data PTC

	Single	Triplet	
Tolerance of ϑ_{NAT}	± 5	± 5	K
Reproducibility of ϑ_{NAT}	$\pm 0,5$	$\pm 0,5$	K
Cold resistance R_{25}	≤ 100	≤ 300	Ω
Cold resistance at a cold-conductor temperature of $\vartheta_{NAT} -5K$	≤ 550	≤ 1650	Ω
Cold resistance at a cold-conductor temperature of $\vartheta_{NAT} +5K$	≥ 1330	≥ 3990	Ω
Cold resistance at a cold-conductor temperature of $\vartheta_{NAT} +15K$	≥ 4	≥ 12	k Ω
Thermal response time t_a	≤ 5	≤ 5	s

7. Meaning of the clamp connections

Clamps	Function	State	Description of the functions
1-2	start	closed	control activated
		open	stand-by, ready for operation
3-4	reset (push button)	actuated	reset faults (e.g: over temperature, PTC-input, phase failure, undervoltage)
5-6	PTC-input	X	deactivation of the power unit on overload
	bridge		wiring without PTC-sensor
7	U_{control} -input	0...10V, 0...20mA, 2,5...10k Ω (reference: Ground, Clamp 8)	input of voltage and current signal or potentiometer control
8	ground (GND)	X	ground for current, voltage, inverse, PWM and potentiometer control
9-10	lock (opening contact)	closed	output voltage on T1, T2 T3
		open	deactivation of the power unit
11	inverse input	10...0V (reference: Ground, Clamp 8)	input of inverse voltage signal (10...0V)
12	PWM-input	5V/5...10kHz	input of PWM-signal (pulse width modulation) ($v_t = 0...1$)
13-14-15	fault relay output	13-14 closed	switching at fault
16-17-18	relay output S2	16-17 closed	switching at output voltage T1,T2,T3 ($U_{\text{Load}} = 100\%$)
19-20-21	relay output S1	19-20 closed	switching at output voltage T1, T2, T3 ($U_{\text{Load}} > 0V$)
22-24	not connected	X	X

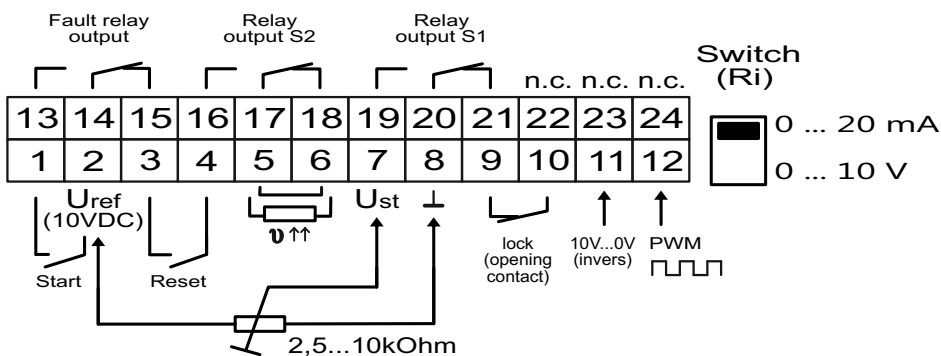

Note:
The black square on the switch picture shows the slide control.



Indicating LEDs during operation:

Pos.	LED 1	LED 2 (S1)	LED 3 (S2)	LED 4	State	Control voltage	S1-relay output (at the same time with LED 2)	S2-relay-output (at the same time with LED 3)
1	green	*	*	*	<ul style="list-style-type: none"> device is ready for use 	0V	ter. 20-21 closed	ter. 17-18 closed
2	green	green	*	*	<ul style="list-style-type: none"> "Start" is enabled (ter. 1 and 2 connected) 	0V	ter. 20-21 closed	ter. 17-18 closed
3	green	orange	*	yellow 0...100%	<ul style="list-style-type: none"> device is ready for use "Start" is enabled U_{Load} amounts to 0...100% LED 4 lights depending on the input voltage 0...100% 	0...100%	ter. 19-20 closed	ter. 17-18 closed
4	green	orange	yellow	yellow 100%	<ul style="list-style-type: none"> device is ready for use "Start" is enabled U_{Load} is 100% LED 4 lights 100% 	100%	ter. 19-20 closed	ter. 16-17 closed
5	green	orange	yellow	yellow 100%	<ul style="list-style-type: none"> device is ready for use "Start" was disabled (ter. 1 and 2 open) LED 2 (S1) lights red for a short moment LED 2, 3, 4 die out 	100%	at the beginning ter. 19-20 are closed; as soon as LED 2 (S1) dies out, ter. 20-21 are closed	at the beginning ter. 16-17 are closed; as soon as LED 3 (S2) dies out, ter.17-18 are closed
6	green	orange	*	yellow 100...0%	<ul style="list-style-type: none"> device is ready for use "Start" was disabled (ter. 1 and 2 open) LED 2 (S1) lights red for a short moment LED 2 and 4 die out 	0...100%	at the beginning ter. 19-20 are closed; as soon as LED 2 (S1) dies out, ter. 20-21 are closed	ter. 17-18 closed

* no change

8. Meaning of the LEDs and clamp connections

(gr) Ready
(rd) Fault





(gr) Start
(or) Run

U Load 100%

Level

TAnlauf
Time Ramp up



LED 1	green	ready for use
	red	lights at fault and load voltage (U_{Load}) on T1, T2, T3 will be switched off
LED 2 (S1)	green	lights as soon as clamps 1-2 (Start) are bridged
	orange	lights if load voltage (U_{load}) on T1, T2, T3 > 0V
LED 3 (S2)	yellow	lights at load voltage (U_{Load}) = 100%
LED 4	yellow	lights depending on the level of the control signal
T_{ramp up}		adjusting of the ramp-up time 0...10s

Tyco-3Ph

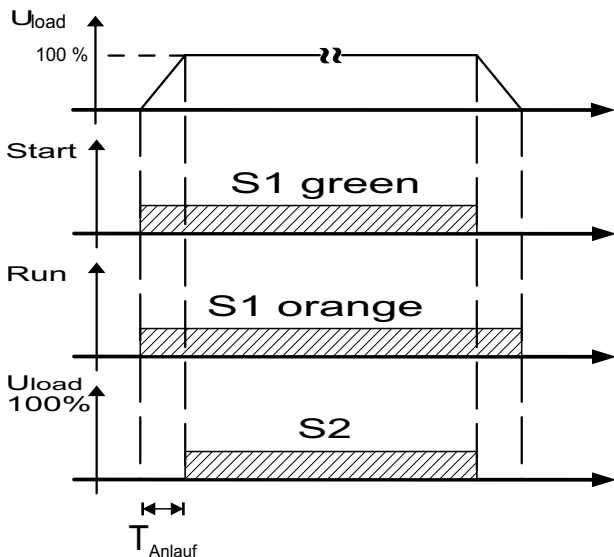

switching function S1 was accomplished (connectors S1 and LED 2 (S1) (orange) are activated at the same time)

switching function S2 was accomplished (connectors S2 and LED 3 (S2) are activated at the same time)

Indicating LEDs at fault:

Pos.	LED 1	LED 2 (S1)	LED 3 (S2)	LED 4	State	Control voltage	S1-relay-output	S2-relay-output	Fault	Solution
7	red	*	*	*	<ul style="list-style-type: none"> device is ready for use fault signal is flashing 	0...100%	ter. 20-21 closed	ter. 17-18 closed	<ul style="list-style-type: none"> PTC released ter. 5-6 open 	check ter. 5 and 6 for proper connection (e.g. bridge, PTC-sensor, contacts)
									<ul style="list-style-type: none"> temperature exceedance of heat sink overload too high load current ambient temperature exceedance 	<ul style="list-style-type: none"> cool down the device check load check power input switch-off temperature threshold is at approx. 85°C
									<ul style="list-style-type: none"> one or more phases are not connected with the net L1, L2, L3 undervoltage 	<ul style="list-style-type: none"> check connections L1, L2, L3 check mains voltage device reacts to mains voltage smaller than 300V
8	red	green	*	*	<ul style="list-style-type: none"> device is ready for use "Start" is enabled fault signal is flashing 	0...100%	ter. 20-21 closed	ter. 17-18 closed	cf. pos. 7	cf. pos. 7
9	green	green	*	*	<ul style="list-style-type: none"> device is ready for use "Start" is enabled 	0...100%	ter. 20-21 closed	ter. 17-18 closed	no operation	check ter. 9 and 10 (closed)

* no change

9. Description of the control inputs

Control with voltage signal:

Switch (Ri)	set 0...10V (Ri>50kΩ)	
Clamp:	7	input signal (0...10V)
	8	GND



Control with current signal:

Switch (Ri)	set 0...20mA	
Clamp:	7	input signal (0...20mA)
	8	GND



Control with potentiometer 2,5-10kΩ:

Switch (Ri)	set 0...10V (Ri>50kΩ)	
Clamp:	2	10 V reference voltage (supply voltage for potentiometer control)
	7	sliding contact
	8	GND



Control with inverse signal:

Switch (Ri)	set 0...20mA	
Clamp:	11	signal input 10...0V
	8	GND

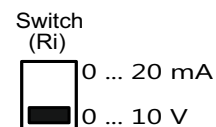

Controlling with pulse width modulation (PWM):

Switch (Ri)	set 0...20mA	
Clamp:	12	signal input 5V, 5...10kHz
	8	GND

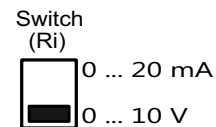

Note: The black square on the switch picture shows the slide control.

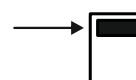

10. Basic circuit

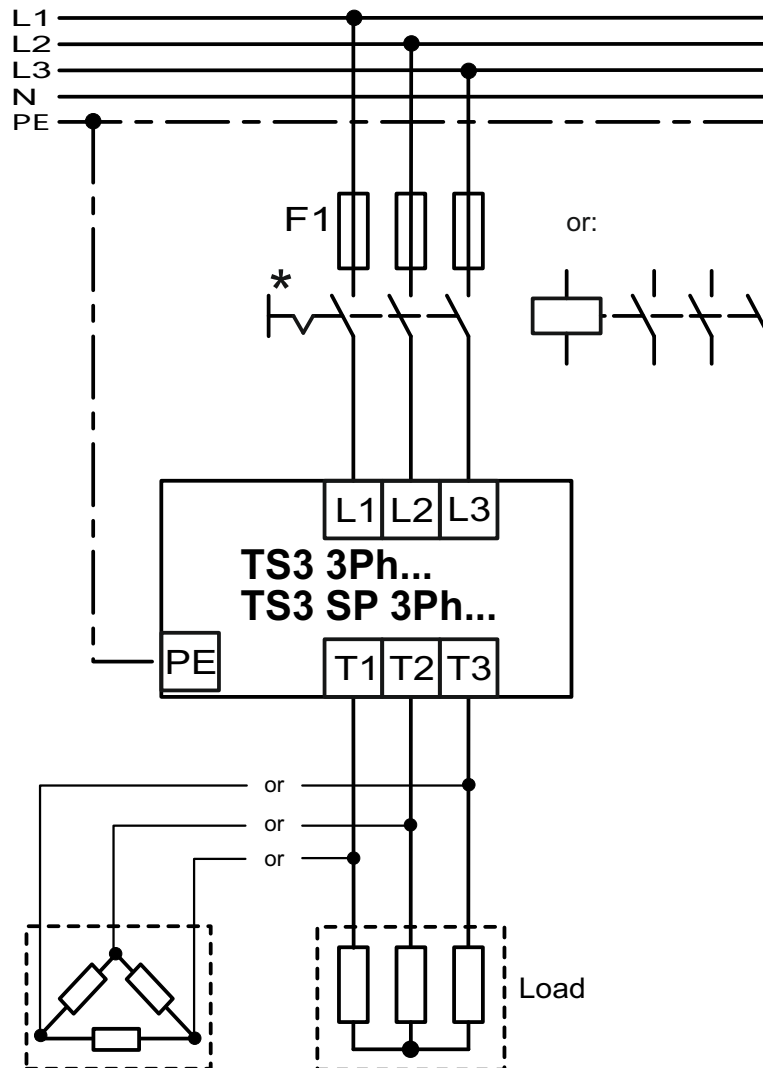

* For disconnection plug connectors, fuses, circuit-breakers, load-breakers, residual current devices (RCDs), etc. can be used.

10.1 Basic circuit for TS3 3Ph... or TS3 SP 3Ph... with control clamps

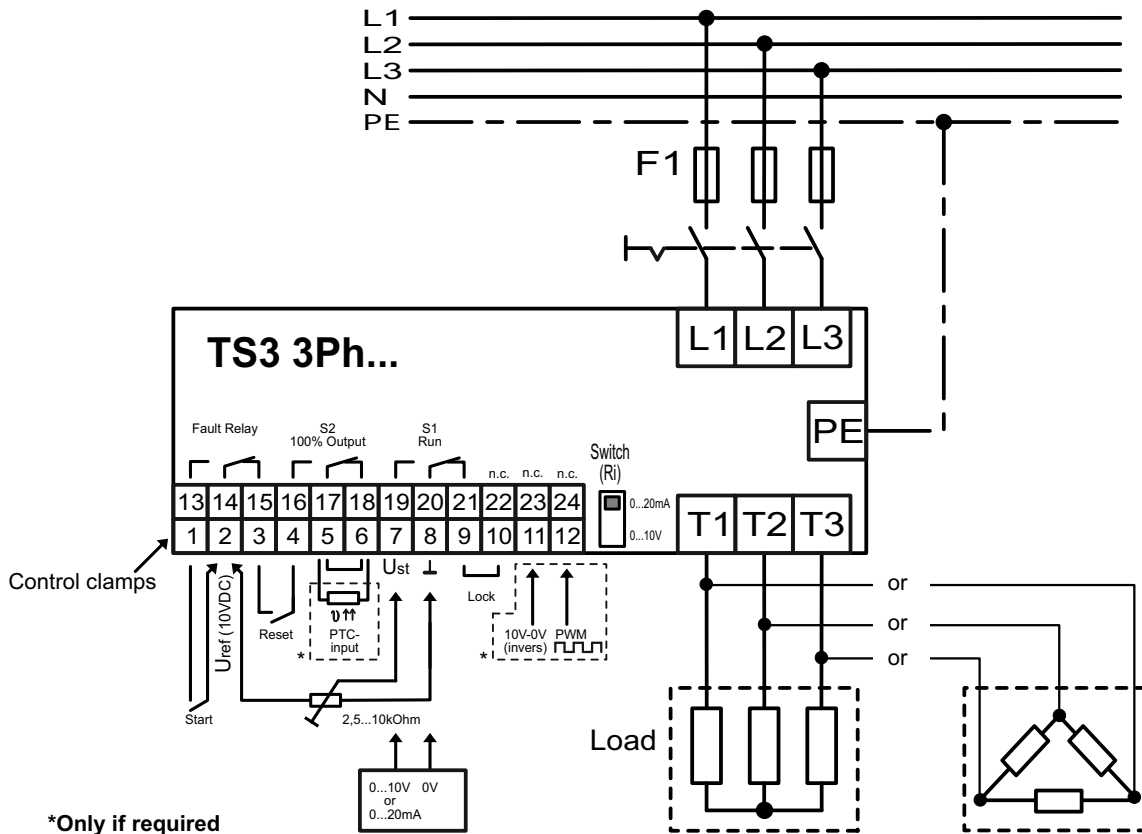

TS3 3Ph.../UM: Switching between phase angle control and multicycle control

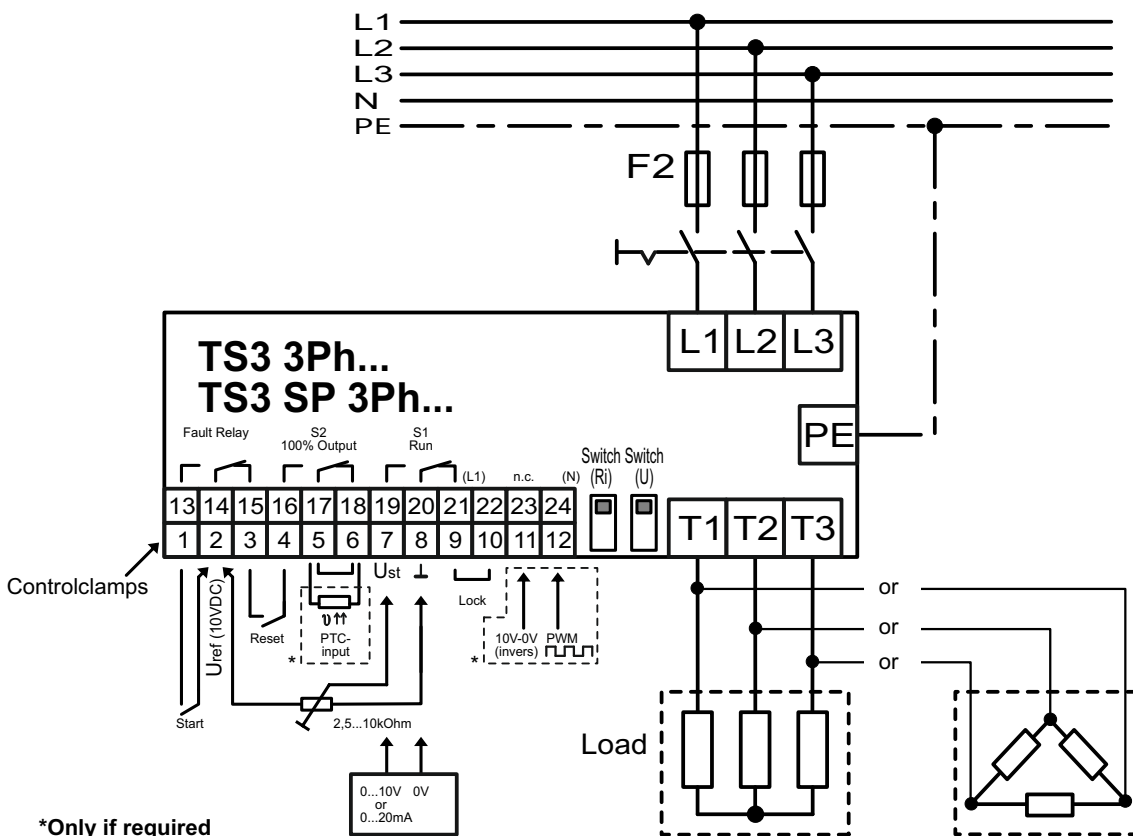

11. Survey of the individual types

Type*	max. load current	rec. semi-conductor fuses	mains fuse	rec. cross-section	max. power	power loss at nominal rating	Weight	Dimensions WxHxD
	[A]	[A]	[A]	[mm ²]	[kW]	[W]	[kg]	[mm]
TS3 3Ph 05	5	10	16	1,5	3	13	1,45	109x200x140**
TS3 3Ph 15	15	25	25	2,5	10	40	1,65	139x200x140
TS3 3Ph 25	25	30	35	4	16	67	1,85	139x200x140
TS3 3Ph 35	35	40	50	6	23	94	1,95	139x200x140
TS3 3Ph 50	50	60	63	10	33	135	1,95	139x200x140

Errors and technical modifications excepted (Date: 2018/06)

* The given details also apply to the version with multicycle control TS3 SP 3Ph...

** without external fan

The given values refer to the operation voltage of 3x 400V AC. The values given for overload refer to a surrounding temperature exceed of max. 50°C and an installation altitude of 1000m.

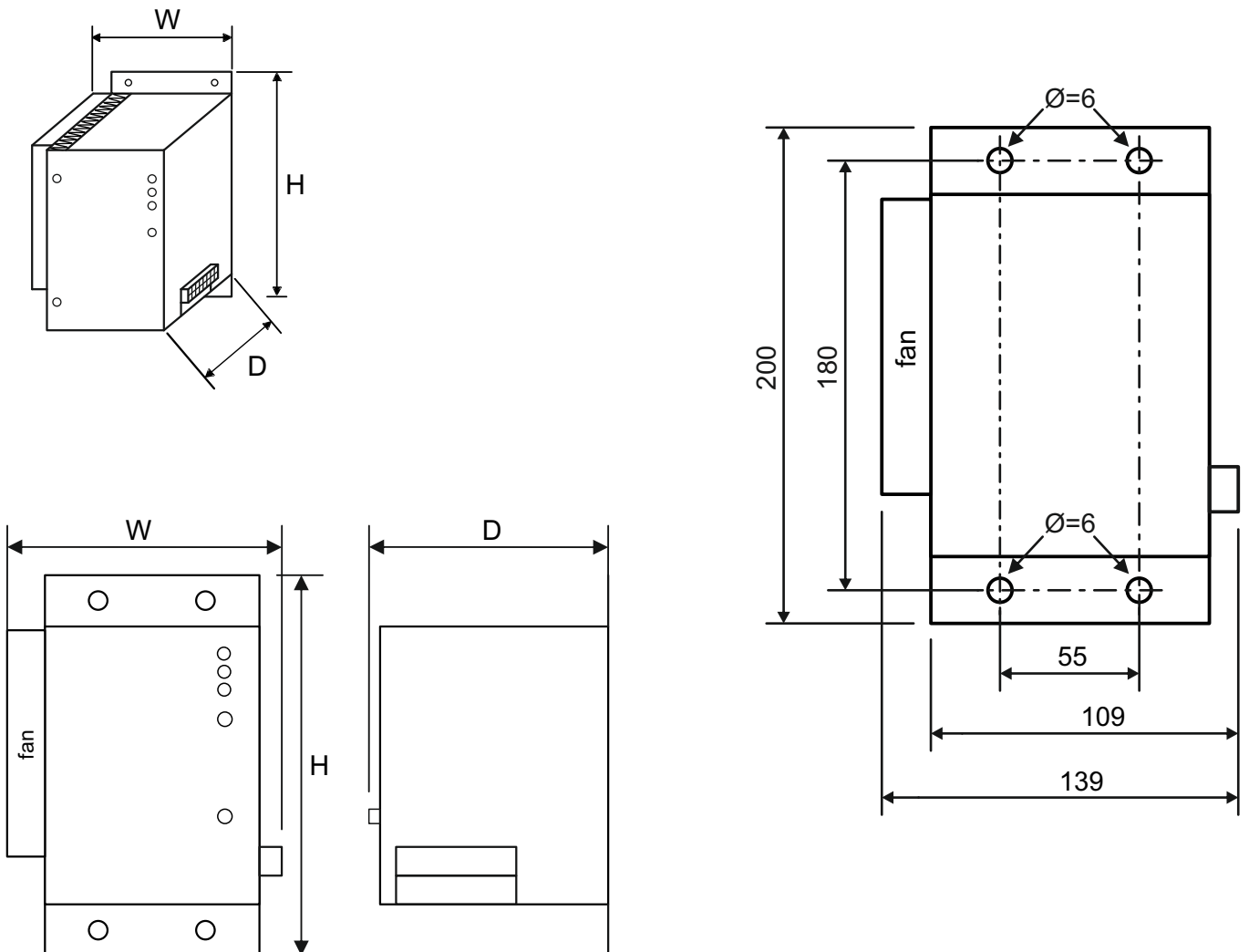

12. Technical data

	TS3 3Ph 05	TS3 3Ph 15	TS3 3Ph 25	TS3 3Ph 35	TS3 3Ph 50
Mains voltage	3x 400V AC +/- 15% (optional: further mains voltages available)				
Rated controller current	5A	15A	25A	35A	50A
Auxiliary voltage	generation internally				
Frequency	45...65Hz, self-synchronizing				
Input	<ul style="list-style-type: none"> • 0...10V • 0...20mA • potentiometer: 2,5...10kΩ • 10...0V inverse input • 5V/5...10kHz input for PWM 				
Input resistance	switchable input resistance: 500 Ω , 50k Ω				
Protetction system	phase failure control and over temperature control (red LED "Fault" and deactivation)				
LED-Display	operation, "Start", "Run", "100% U _{Load} ", "Fault", level				
Possible adjustments	ramp-up time: 0...10s				
Control outputs	<ul style="list-style-type: none"> • fault condition: ter. 13,14 closed; contact rating: 2A, 230V AC, AC1; • S1-relay output: ter. 19,20 closed; contact rating: 2A, 230V AC, AC1; • S2-relay output: ter. 16,17 closed; contact rating: 2A, 230V AC, AC1; 				
Power terminals	<ul style="list-style-type: none"> • L1, L2, L3 input voltage • T1, T2, T3 output voltage 				
Kind of controlling	phase angle control (optional: multicycle control)				
Power loss	0,9W x 3/A				
Operating temperature	0...50°C				
Storage temperature	-10...70°C				
Humidity	5...95% relative humidity, not condensing				
Enviroment	dry and non-conducting environments				
Max. altitude	1000m				
Weight	1,45kg	1,65kg	1,85kg	1,95kg	1,95kg
Protection	IP 40				
Installation	vertically, power terminals below				
Dimensions (WxHxD)	109(with fan 139)x200x140mm				
Mounting	for screw mounting in a enclosure				
CE-marking	DECLARATION OF CONFORMITY: 2014/35/EU (low voltage directive), EMC Directive: 2014/30/EU for industrial environments				
Regulations	VDE 0160, EN 60204				

Errors and technical modifications excepted (Date: 2018/06)

13. Options and equipment

Options:

- current output 0...10V (/AI)
- current limitation by phase angle control (/IB)
- neutral wire connection with SP (/N)
- without phase failure control (/OA)
- external auxiliary voltage /24VDC, /230VAC, /110VAC
- switching between phase angle control (Ph) and multicycle control (SP).:/UM
- output power signal 0...10V (/AP)
- output voltage signal 0...10V (/AU)
- application for 35mm-DIN rail (/NS)
- kind of protection IP 55 (/IP55)
- kind of protection IP 65 (/IP65)