

# » AGS55+ Basic RS485 Modbus

Outdoor temperature sensor

**thermokon**<sup>®</sup>  
HOME OF SENSOR TECHNOLOGY

## Datasheet

Subject to technical alteration  
Issue date: 01.03.2021 • A112



## » APPLICATION

Sensor for outdoor temperature measurement: cold rooms, greenhouses, production plants and warehouses. Stainless Steel external probe for faster response.

## » TYPES AVAILABLE

Outdoor sensor temperature – active BUS

AGS55+ RS485 Modbus

## » SECURITY ADVICE – CAUTION



The installation and assembly of electrical equipment should only be performed by authorized personnel.

The product should only be used for the intended application. Unauthorised modifications are prohibited! The product must not be used in relation with any equipment that in case of a failure may threaten, directly or indirectly, human health or life or result in danger to human beings, animals or assets. Ensure all power is disconnected before installing. Do not connect to live/operating equipment.

Please comply with

- Local laws, health & safety regulations, technical standards and regulations
- Condition of the device at the time of installation, to ensure safe installation
- This data sheet and installation manual

## » NOTES ON DISPOSAL



As a component of a large-scale fixed installation, Thermokon products are intended to be used permanently as part of a building or a structure at a pre-defined and dedicated location, hence the Waste Electrical and Electronic Act (WEEE) is not applicable. However, most of the products may contain valuable materials that should be recycled and not disposed of as domestic waste. Please note the relevant regulations for local disposal.

## » GENERAL REMARKS CONCERNING SENSORS

Especially with regard to passive sensors in 2-wire conductor versions, the wire resistance of the supply wire has to be considered. If necessary the wire resistance has to be compensated by the follow-up electronics. Due to self-heating, the wire current affects the measurement accuracy, so it should not exceed 1 mA.

When using lengthy connection wires (depending on the cross section used) the measuring result might be falsified due to a voltage drop at the common GND-wire (caused by the voltage current and the line resistance). In this case, 2 GND-wires must be wired to the sensor - one for supply voltage and one for the measuring current.

Sensing devices with a transducer should always be operated in the middle of the measuring range to avoid deviations at the measuring end points. The ambient temperature of the transducer electronics should be kept constant. The transducers must be operated at a constant supply voltage ( $\pm 0,2$  V). When switching the supply voltage on/off, onsite power surges must be avoided.

## » BUILD-UP OF SELF-HEATING BY ELECTRICAL DISSIPATIVE POWER

Temperature sensors with electronic components always have a dissipative power, which affects the temperature measurement of the ambient air. The dissipation in active temperature sensors shows a linear increase with rising operating voltage. This dissipative power has to be considered when measuring temperature. In case of a fixed operating voltage ( $\pm 0,2$  V) this is normally done by adding or reducing a constant offset value. If a re-calibration should become necessary later directly on the sensor, this can be done by means of a trimming potentiometer on the sensor board. As Thermokon transducers work with a variable operating voltage, only one operating voltage can be taken into consideration, for reasons of production engineering. Transducers have a standard setting at an operating voltage of 24 V =. That means, that at this voltage, the expected measuring error of the output signal will be the least. For other operating voltages, the offset error will be increased by a changing power loss of the sensor electronics.

**Remark: Occurring draft leads to a better carrying-off of dissipative power at the sensor. Thus temporally limited fluctuations might occur upon temperature measurement.**

## » MOUNTING ADVICES

In case of outdoor installation avoid direct rain and sun contact. Probably use sun respectively rain protection. Cable entry from bottom or side. For side cable routing set loop so that precipitation can drain defined. Observe permissible ambient condition.

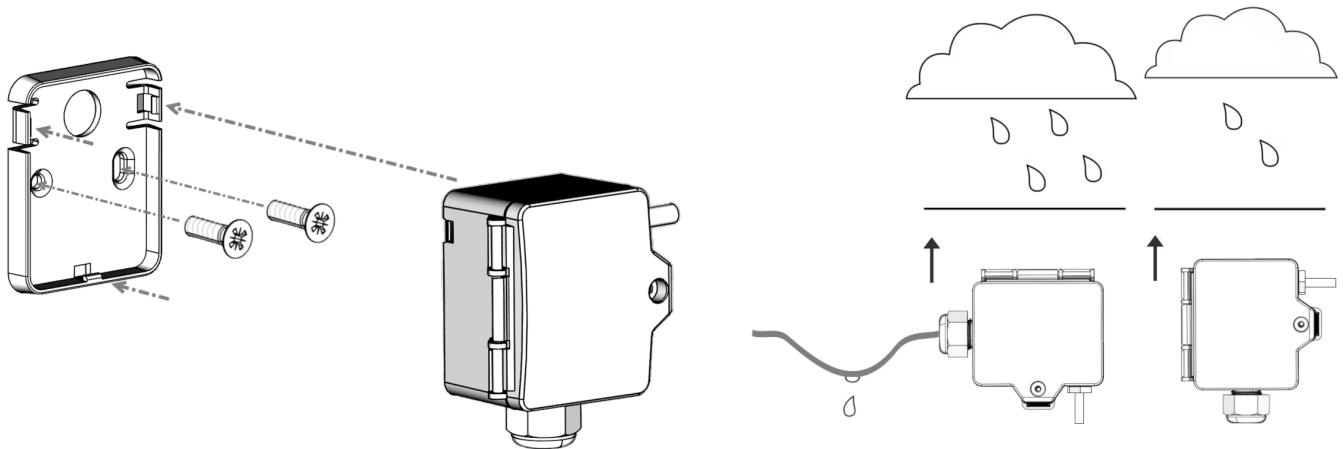

## » PRODUCT TESTING AND CERTIFICATION



**Declaration of conformity**

The declaration of conformity of the products can be found on our website <https://www.thermokon.de/>.

## » USE ENCLOSURE WITH UV AND WEATHER RESISTANCE

After some time, outdoor mounted plastics can lose their color and quality. Therefore, all USE housings are made of special white polycarbonate (PC). The light-stable colorants and additives are used to achieve optimum protection of the polymer while maintaining color stability. The titanium dioxide used is specially developed for polycarbonate and offers excellent UV protection through the reflection of the entire light spectrum including the UV component by 340 nm. This effectively counteracts the otherwise occurring photochemical polymer degradation. The colors stay full for a long time without fading. The material is also resistant to cold and frost.

» **TECHNICAL DATA**

Measuring values	temperature
Network technology	RS485 Modbus, RTU or ASCII, half-duplex, baud rate 9.600, 19.200, 38.400 or 57.600, parity: non (2 stopbits), even or odd (1 stopbit)
Power supply	15..24 V = (±10%) (or 24 V ~ (±10%))* SELV
Power consumption	max. 0,7 W (24 V =)   1,8 VA (24 V ~) SELV
Operating temp range	max. permissible operating temperature -35..+70 °C
Accuracy temperature	±0,5 K (typ. at 25 °C)
Enclosure	enclosure USE-S, PC, pure white, UV resistant
Protection	IP65 according to EN 60529, SI-Protection
Cable entry	Flextherm M20, for wire Ø=4,5..9 mm, removable
Connection electrical	removable plug-in terminal, max. 2,5 mm <sup>2</sup>
Pocket	stainless steel V2A, Ø=6 mm, L=25 mm
Ambient condition	max. 85% rH short term condensation

» **CONNECTION PLAN AND CONFIGURATION**

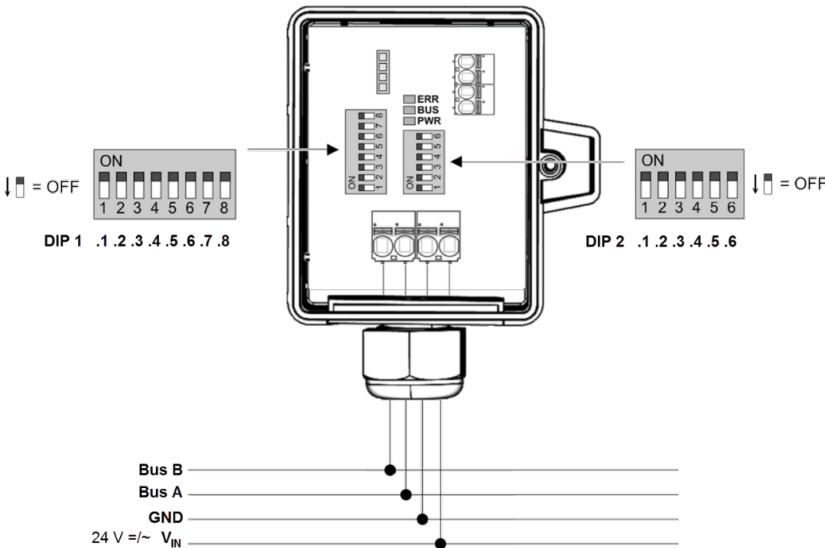

**Power supply**

When several BUS devices are supplied by one 24 V AC voltage supply, it is to be ensured that all “positive” operating voltage input terminals (+) of the field devices are connected with each other and all “negative” operating voltage input terminals (-) (=reference potential) are connected together (in-phase connection of field devices).

In case of reversed polarity at one field device, a supply voltage short-circuit would be caused by that device. The consequential short-circuit current flowing through this field my cause damage to it.

**Therefore, pay attention to correct wiring.**

LED	Description
ERR	Indicator for error notification
BUS	Indicator for RS485 traffic
PWR	Power supply

**Device Address (binary coded)**

DIP 1.1	DIP 1.2	DIP 1.3	DIP 1.4	DIP 1.5	DIP 1.6	DIP 1.7	DIP 1.8	Address
2 <sup>0</sup>	2 <sup>1</sup>	2 <sup>2</sup>	2 <sup>3</sup>	2 <sup>4</sup>	2 <sup>5</sup>	2 <sup>6</sup>	2 <sup>7</sup>	
ON	OFF	OFF	OFF	OFF	OFF	OFF	OFF	1
OFF	ON	OFF	OFF	OFF	OFF	OFF	OFF	2
ON	ON	OFF	OFF	OFF	OFF	OFF	OFF	3
								...
ON	ON	ON	ON	ON	ON	ON	ON	247

**Modbus interface settings**

DIP 2.1	Mode	DIP 2.2	DIP 2.3	Baud	DIP 2.4	DIP 2.5	Parity	DIP 2.6	Register
OFF	RTU	OFF	OFF	9.600	ON	OFF	even	OFF	UNI
ON	ASCII	ON	OFF	19.200	OFF	ON	odd	ON	USE
		OFF	ON	38.400	OFF	OFF	none (2 Stopbits)		
		ON	ON	57.600	ON	ON	none (1 Stopbit)		

**Factory default**

Device address: 1 | RTU | Baud rate: 9.600 | Parity: even | Register addressing: USE

**Register compatibility to USE (Valid from firmware version 1.4, Jan. 2020)**

Via dipswitch 2.6 it is possible to change between the previous register addressing of the UNI-Modbus board to a USE compatible register assignment. The function of the device does not change.

**When using ASCII mode, parity must be set to EVEN or ODD. „No Parity“ (no) is not available in ASCII mode.**

**» RS485 MODBUS REGISTER****Variant 1 (UNI-Modbus) DIP 2.6 = OFF**

Data address	Function code	Description	Type
0 <sub>dec</sub>   0x0000 <sub>hex</sub>	3 (R)	Firmware z.B.: 0x1000 = Version 1.0.0.0	SIGNED 16 Bit
1 <sub>dec</sub>   0x0001 <sub>hex</sub>	4 (R/W)	Device Location	SIGNED 16 Bit
580 <sub>dec</sub>   0x244 <sub>hex</sub>	3 (R)	Temperature [1/100] °C	SIGNED 16 Bit
581 <sub>dec</sub>   0x245 <sub>hex</sub>	3 (R)	Temperature [1/100] °F	SIGNED 16 Bit
5 <sub>dec</sub>   0x0005 <sub>hex</sub>	4 (R/W)	Offset temperature [1/100] K	SIGNED 16 Bit

**Variant 2 (USE-Modbus) DIP 2.6 = ON**

Data address	Function code	Description	Type
503 <sub>dec</sub>   0x01F7 <sub>hex</sub>	3 (R)	Firmware version i.e.: 0x1300 = Version 1.3.0.0	SIGNED 16 Bit
400 <sub>dec</sub>   0x0190 <sub>hex</sub>	4 (R/W)	Unit system 1 = SI 2 = Imperial	SIGNED 16 Bit
0 <sub>dec</sub>   0x0000 <sub>hex</sub>	3 (R)	Temperature [1/10] °C/°F	SIGNED 16 Bit
100 <sub>dec</sub>   0x0100 <sub>hex</sub>	4 (R/W)	Offset temperature [1/10] K	SIGNED 16 Bit

## » DIMENSIONS (MM)

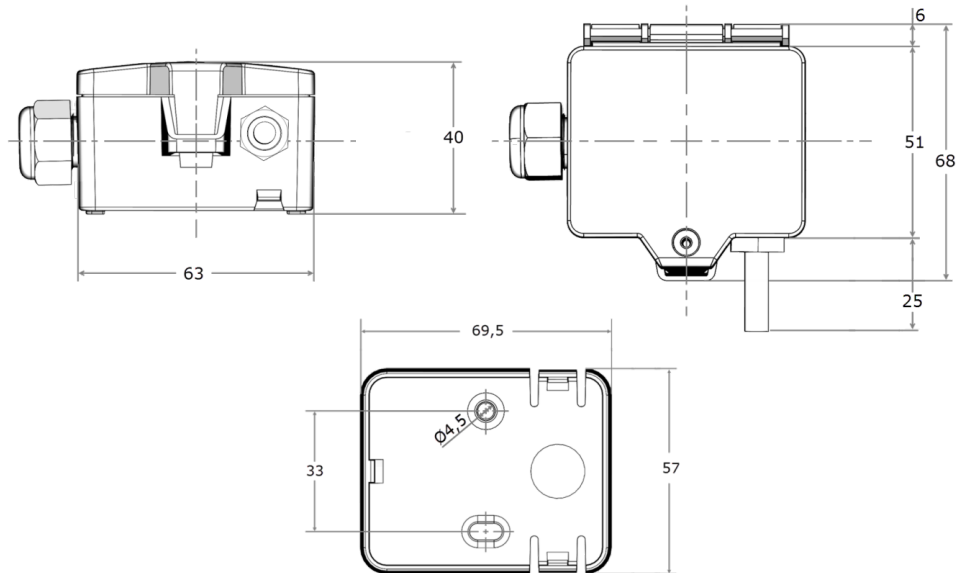

## » ACCESSORIES (INCLUDED IN DELIVERY)

Mounting base enclosure USE pure white

Item No. 667722

Mounting kit universal

Item No. 698511

• Cover screw + screw cover • 2 Rawlplugs • 2 Screws (countersunk head) • 2 Screws (rounded head)

## » ACCESSORIES (OPTIONAL)

Mounting clip enclosure USE pure white

Item No. 667739

Sun/rain protection RS150

Item No. 103329

Sealing insert M20 USE white, 2x Ø=7 mm (for 2 wire; PU 10 pieces)

Item No. 641333