

Datasheet

Subject to technical alteration
Issue date: 09.12.2019 • A100



LON
LOCAL OPERATING NETWORK

» APPLICATION

Ceiling mounted multi sensor designed for measuring light and motion in room and office spaces and typically used in lighting applications to optimize energy efficiency through lighting control and temperature reduction in unused rooms. Low profile design with various output signals compatible to all BMS manufacturers. For mounting on concrete ceilings an enclosure for surface mounting is available.

» TYPES AVAILABLE

Ceiling multi sensor light + motion – active BUS

MDS LON 1

Ceiling multi sensor light + motion + temperature – active BUS

MDS LON 2

» SECURITY ADVICE – CAUTION



The installation and assembly of electrical equipment should only be performed by authorized personnel.

The product should only be used for the intended application. Unauthorised modifications are prohibited! The product must not be used in relation with any equipment that in case of a failure may threaten, directly or indirectly, human health or life or result in danger to human beings, animals or assets. Ensure all power is disconnected before installing. Do not connect to live/operating equipment.

Please comply with

- Local laws, health & safety regulations, technical standards and regulations
- Condition of the device at the time of installation, to ensure safe installation
- This data sheet and installation manual

» NOTES ON DISPOSAL



As a component of a large-scale fixed installation, Thermokon products are intended to be used permanently as part of a building or a structure at a pre-defined and dedicated location, hence the Waste Electrical and Electronic Act (WEEE) is not applicable. However, most of the products may contain valuable materials that should be recycled and not disposed of as domestic waste. Please note the relevant regulations for local disposal.

» BUILD-UP OF SELF-HEATING BY ELECTRICAL DISSIPATIVE POWER

Temperature sensors with electronic components always have a dissipative power, which affects the temperature measurement of the ambient air. The dissipation in active temperature sensors shows a linear increase with rising operating voltage. This dissipative power has to be considered when measuring temperature. In case of a fixed operating voltage ($\pm 0,2$ V) this is normally done by adding or reducing a constant offset value. As Thermokon transducers work with a variable operating voltage, only one operating voltage can be taken into consideration, for reasons of production engineering. Transducers 0..10 V / 4..20 mA have a standard setting at an operating voltage of 24 V =. That means, that at this voltage, the expected measuring error of the output signal will be the least. For other operating voltages, the offset error will be increased by a changing power loss of the sensor electronics. If a recalibration is necessary during later operation, this is via a corresponding software variable for devices with BUS interface.

» PRODUCT TESTING AND CERTIFICATION



Declaration of conformity

The declaration of conformity of the products can be found on our website <https://www.thermokon.de/>.

» TECHNICAL DATA

Measuring values <i>(type-dependent)</i>	Brightness, motion, optional temperature
Network technology	LON FT (free topology)
Power supply	15..24 V = ($\pm 10\%$) or 24 V ~ ($\pm 10\%$) SELV
Power consumption	typ. 1,5 W (24 V =) 4 VA (24 V ~)
Measuring range temperature <i>(type-dependent)</i>	0..+50 °C
Measuring range light	0..1000 Lux
Accuracy temperature <i>(type-dependent)</i>	$\pm 0,5$ K (typ. at 21 °C)
Accuracy light	± 50 Lux
Detection range	Cone-shaped detection range, angle 105°, range > 5 m, 444 detection zones. With an installation height of 2,7 m circular detection range will have a R= 7 m.
Sensor	PIR (passive infrared)
Enclosure	ABS, pure white
Protection	IP20 according to EN 60529
Connection electrical	terminal, max. 1,5 mm ² , plugable
Ambient condition	0..+50 °C, max. 85% rH non-condensing
Notes	Enclosure for surface mounting available

» **MOUNTING ADVICES**

Mountiung hight

The mounting height has a direct influence on the range of the motion detector. The optimum mounting height is 2.70m. All other dimensions will change the range.

Fixed mounting

The motion detector must be mounted on a solid surface, as any movement of the detector will result in false alarms.

Distance to switched luminaires

In order to avoid unintentional switching on of the luminaire by the motion detector, the luminaire should not be mounted in the detection area of the motion detector. Also avoid mounting the motion detector above a luminaire. The heat radiation of the luminaire can influence the function of the motion detector and possibly lead to a false triggering of the detector.

Mounting sideways to the walking direction

For optimum motion detection, the detector must be mounted to the side of the detection area so that the zones are cut as vertically as possible. Mounting locations where the objects to be detected move directly onto the motion detector result in a significant reduction of the range.

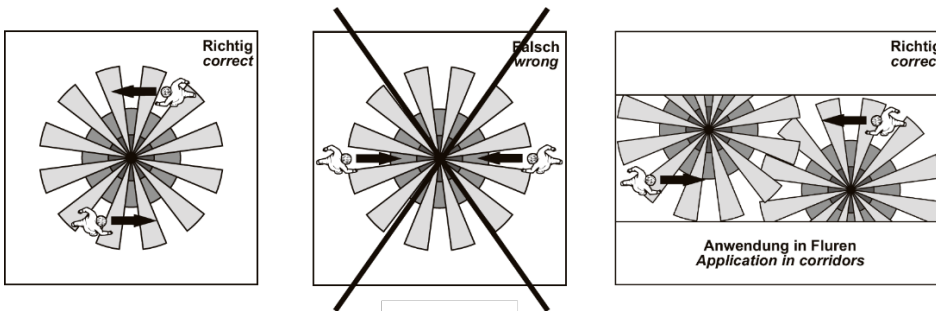

Distance to interference sources

To avoid false alarms, sources of interference such as radiators, lamps, air outlets from air conditioning systems, etc. should be outside the detection range. Direct sunlight should also be avoided.

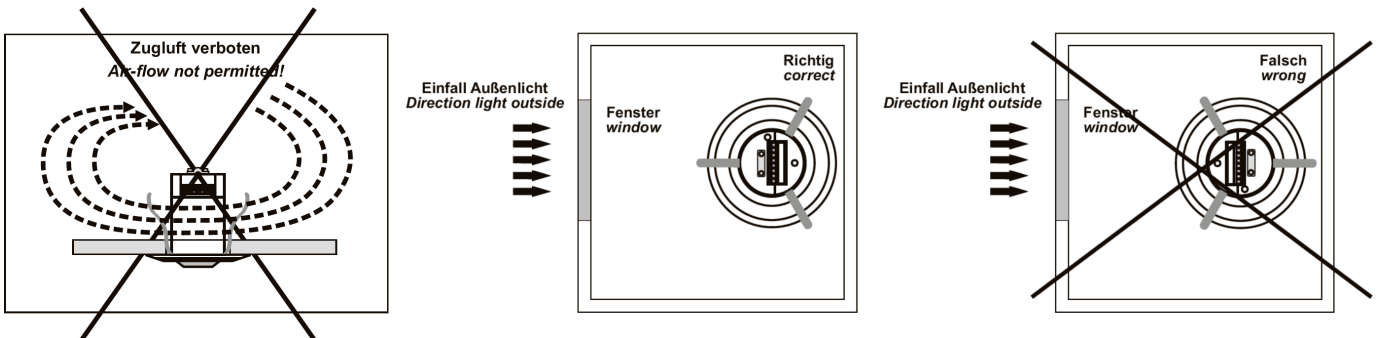

Feedback on detected movement

Motion detection by the sensor is signalled by the integrated signal LED (flashing for approx. 2 seconds). Note: The signalling LED is independent of the set follow-up time of the relay output. During initialisation of the device (voltage reset), the signalling LED and the relay output are switched on for approx. 45 seconds.

» **DETECTION RANGE**

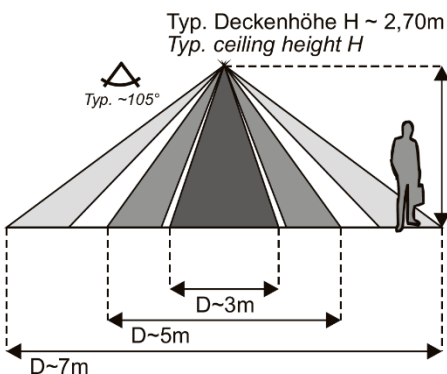

This sensor detects changes in infrared radiation that occur when a person (or object) moves whose temperature is different from the environment.

The specified ranges refer to average conditions at a certain installation height and are therefore to be regarded as guide values. The range can vary greatly with changing temperature conditions. The necessary temperature difference between the detectable object and the environment should be at least 4 K. The speed of the object should be at least 0.3 to 1.0 m/s.

» CONNECTION PLAN

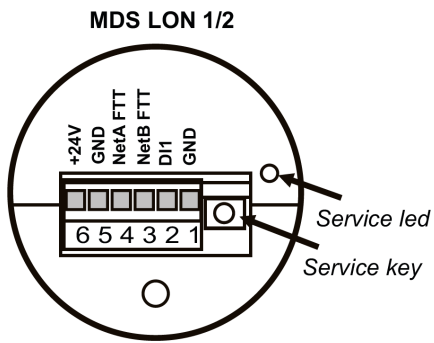

» DIMENSIONS (MM)

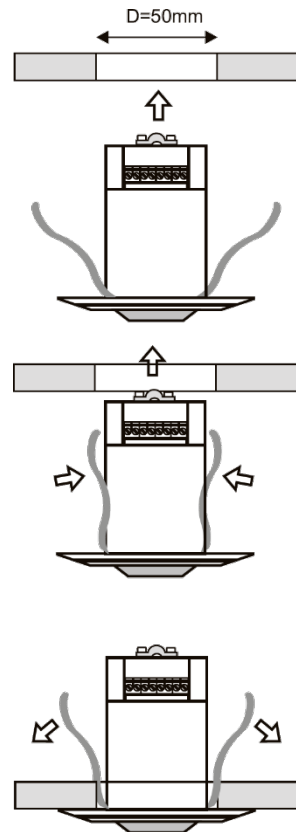
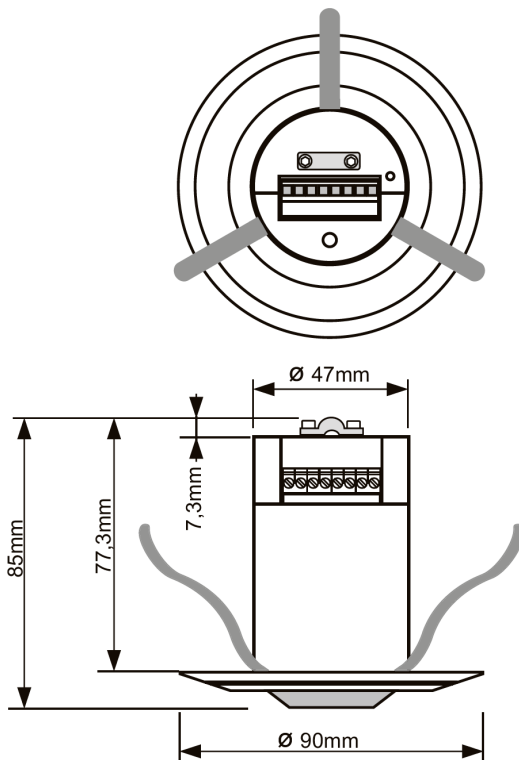

» ACCESSORIES (OPTIONAL)

Enclosure for surface mounting MDS pure white

Item No. 448512