

» Li04 LON

Light sensor

thermokon[®]
HOME OF SENSOR TECHNOLOGY

Datasheet

Subject to technical alteration
Issue date: 20.11.2019 • A100



LON
LOCAL OPERATING NETWORK

» APPLICATION

The room brightness sensor with selectable measuring ranges and color filter to adjust the sensitivity similar to the human eye captures the brightness indoors. Designed for controlling lighting or sun protection systems. The device can be mounted directly on the wall, on a flush-mounted box or in conjunction with a frame for surface-mounting (see accessories).

» TYPES AVAILABLE

Light sensor- active LON

Li04 LON

» SECURITY ADVICE – CAUTION



The installation and assembly of the device should only be performed by authorized personnel.

The product should only be used for the intended application. Unauthorised modifications are prohibited! The product must not be used in relation with any equipment that in case of a failure may threaten, directly or indirectly, human health or life or result in danger to human beings, animals or assets. Ensure all power is disconnected before installing. Do not connect to live/operating equipment.

Please comply with

- Local laws, health & safety regulations, technical standards and regulations
- Condition of the device at the time of installation, to ensure safe installation
- This data sheet and installation manual

» NOTES ON DISPOSAL



As a component of a large-scale fixed installation, Thermokon products are intended to be used permanently as part of a building or a structure at a pre-defined and dedicated location, hence the Waste Electrical and Electronic Act (WEEE) is not applicable. However, most of the products may contain valuable materials that should be recycled and not disposed of as domestic waste. Please note the relevant regulations for local disposal.

» TECHNICAL DATA

Measuring values	Luminosity
Network technology	LON FT (free topology)
Power supply	15..24 V = ($\pm 10\%$) or 24 V ~ ($\pm 10\%$) SELV
Power consumption	typ. 0,15 W (24 V =) 0,5 VA (24 V ~)
Measuring range light	0..2 kLux, 0..20 kLux, 0..100 kLux, adjustable at the device
Accuracy light	$\pm 5\%$ of measuring range
Sensor	photodiode with greenfilter
Enclosure	PC, pure white
Protection	IP30 according to EN 60529
Cable entry	breaking points top/bottom, rear entry
Connection electrical	terminal block, max. 1,5 mm ²
Ambient condition	-20..+70 °C, max. 85% rH non-condensing
Mounting	surface mounted on flush-mounting box ($\varnothing=60$ mm), to be mounted flat onto the surface using adhesive foil or screws, with frame for surface mounting (accessory) or directly on the wall, base part can be mounted and wired separately

» PRODUCT TESTING AND CERTIFICATION



Declaration of conformity

The declaration of conformity of the products can be found on our website <https://www.thermokon.de/>.

» MOUNTING ADVICE

Make sure that the device is power-off, if you install it!

The device can be installed on a smooth wall surface or a flush box. It should be selected a representative location for the measuring medias. The use of deep installation boxes is recommended due to the increased storage capacity for the cabling.

Sunlight and drafts e.g. in conduit must be avoided so that the measuring result is not distorted. If necessary, is the end of the installation tube seal

- (1) For wiring, the upper part of the base plate must be solved. Base plate and upper part are connected with each other by mounting clips.
- (2) The installation of the base plate to the smooth wall surface can be done with plugs and screws.
- (3) Then, the device is placed on the base plate.

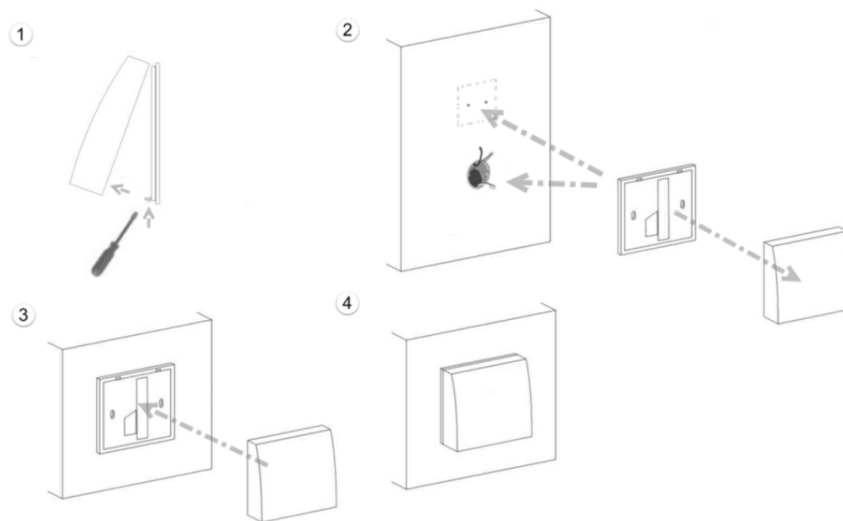

» COMMISSIONING AND CONFIGURATION

Spectral sensitivity

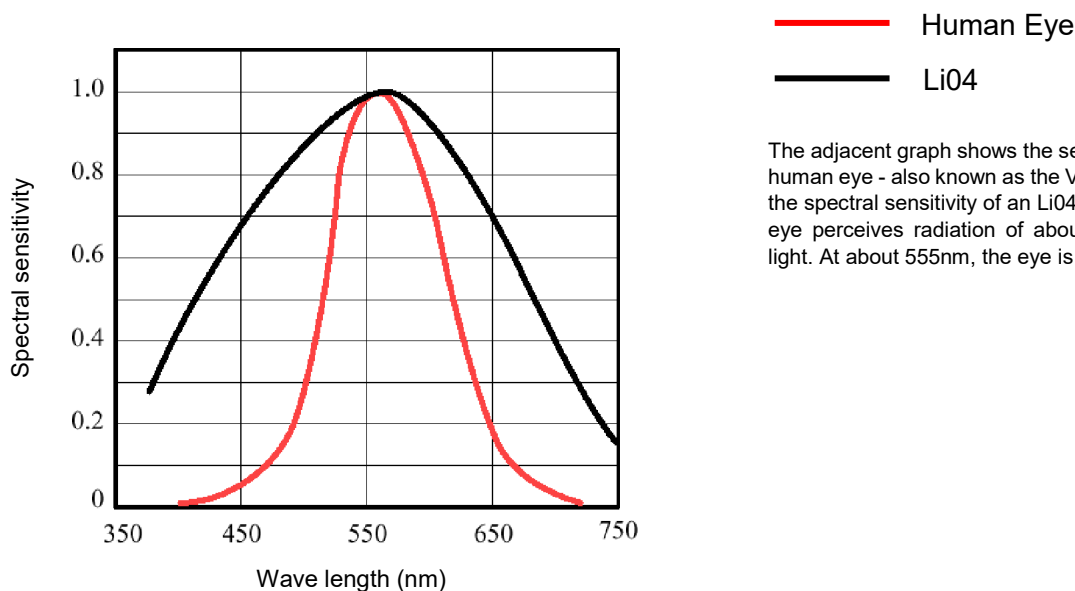

The adjacent graph shows the sensitivity curve of the human eye - also known as the V-lambda curve - and the spectral sensitivity of an Li04 sensor. The human eye perceives radiation of about 400 to 700nm as light. At about 555nm, the eye is most sensitive.

- 1) Sensitivity of sensor without prism. Adjustable by means of DIP-switch on the transducer.
- 2) Accuracy of transducer without prism. Manufacturer's calibration is made in the 2kLux range. Operating voltage 24V= and 21°C (+/- 5K) ambient temperature. Please take care that the transducer should generally be operated in the measuring range centre, as increased deviations could occur on the measuring range end points. In addition the ambient temperature of the transducer electronics should be kept constant.

» CONNECTION PLAN

Dip switches

4	3	2	1	Measuring range
OFF	OFF	OFF	ON	0..2000 Lux
OFF	OFF	ON	OFF	0..20.000 Lux
OFF	ON	OFF	OFF	0..65.535 Lux

Terminal assignment Li04 V (0..10 V)

1	15..24 V = ($\pm 10\%$) or 24 V ~ ($\pm 10\%$) SELV
2	GND
3	Net A
4	Net B

Service Pin/ Service LED
Connect the two pins to send a service pin message

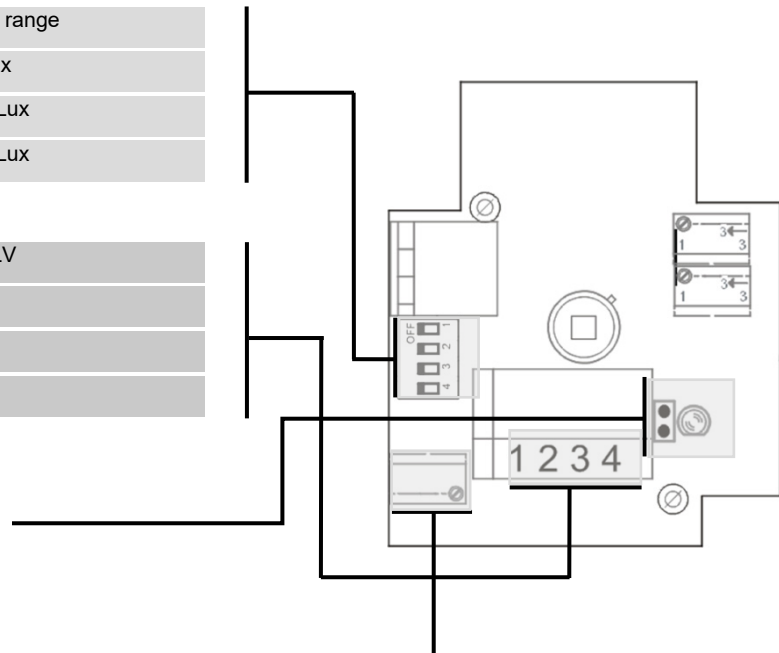

Potentiometer
To adjust the output level to different environments

» DIMENSIONS (MM)

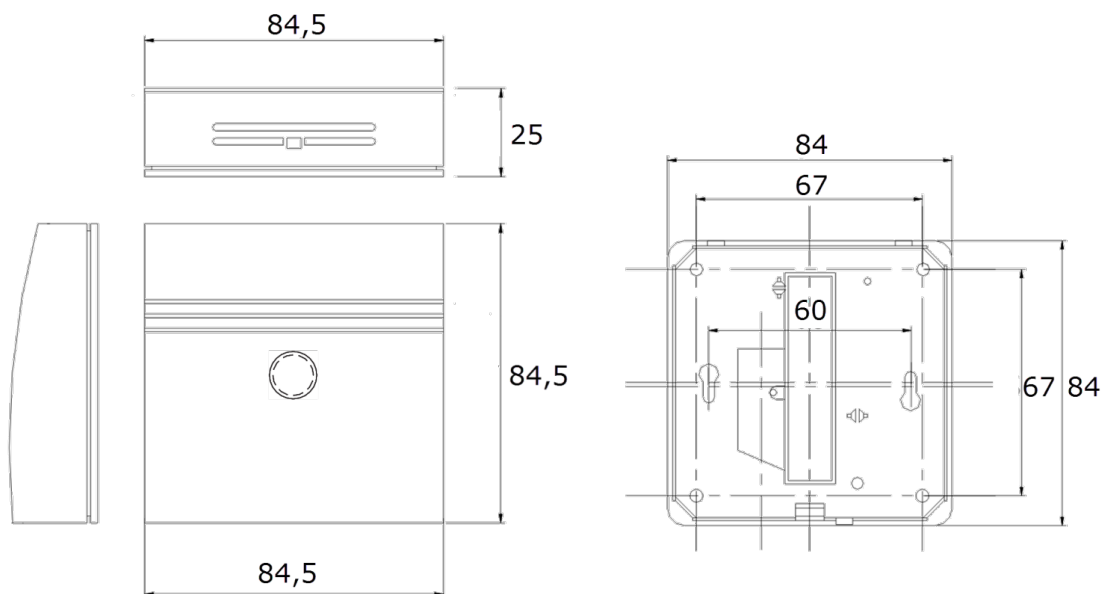

» ACCESSORIES (OPTIONAL)

Raw plugs and screws (2 pcs. each)
PSU-UP24 – flush mount power supply 24 V (80..240 V ~ -> 24 V =, 0,5 A)
Frame for surface mounting WRF04

Item No. 102209
Item No. 645737
Item No. 111584