

Datasheet

Subject to technical alteration
Issue date: 31.01.2017



Application

Duct averaging temperature sensor with flexible sensor rod in the newly developed hinged lid enclosure USE-S for measuring the average temperature in air ducts.

Types Available

Duct averaging sensor temperature – passive

MWF400+ <sensor>

Duct averaging sensor temperature – active TRV 0..10 V | TRA 4..20 mA

MWF400+ TRV MultiRange

MWF400+ TRA MultiRange

<sensor>: Pt100/Pt1000/NTC10k/Ni1000/Ni1000TK5000

MultiRange: Measuring ranges adjustable at the transducer

Security Advice – Caution



The installation and assembly of electrical equipment should only be performed by authorized personnel.

The product should only be used for the intended application. Unauthorised modifications are prohibited! The product must not be used in relation with any equipment that in case of a failure may threaten, directly or indirectly, human health or life or result in danger to human beings, animals or assets. Ensure all power is disconnected before installing. Do not connect to live/operating equipment.

Please comply with

- Local laws, health & safety regulations, technical standards and regulations
- Condition of the device at the time of installation, to ensure safe installation
- This data sheet and installation manual

Notes on Disposal



As a component of a large-scale fixed installation, Thermokon products are intended to be used permanently as part of a building or a structure at a pre-defined and dedicated location, hence the Waste Electrical and Electronic Act (WEEE) is not applicable. However, most of the products may contain valuable materials that should be recycled and not disposed of as domestic waste. Please note the relevant regulations for local disposal.

General remarks concerning to sensors

Especially with regard to passive sensors in 2-wire conductor versions, the wire resistance of the supply wire has to be considered. If necessary the wire resistance has to be compensated by the follow-up electronics. Due to self-heating, the wire current affects the measurement accuracy. So it should not exceed 1 mA.

When using lengthy connection wires (depending on the cross section used) the measuring result might be falsified due to a voltage drop at the common GND-wire (caused by the voltage current and the line resistance). In this case, 2 GND-wires must be wired to the sensor - one for supply voltage and one for the measuring current.

Sensing devices with transducer should always be operated in the middle of the measuring range to avoid deviations at the measuring end points. The ambient temperature of the transducer electronics should be kept constant. The transducers must be operated at a constant supply voltage ($\pm 0,2$ V). When switching the supply voltage on/off, onsite power surges must be avoided.

Build-up of Self-Heating by Electrical Dissipative Power

Temperature sensors with electronic components always have a dissipative power, which affects the temperature measurement of the ambient air. The dissipation in active temperature sensors shows a linear increase with rising operating voltage. This dissipative power has to be considered when measuring temperature. In case of a fixed operating voltage ($\pm 0,2$ V) this is normally done by adding or reducing a constant offset value. As Thermokon transducers work with a variable operating voltage, only one operating voltage can be taken into consideration, for reasons of production engineering. Transducers 0..10 V / 4..20 mA have a standard setting at an operating voltage of 24 V =. That means, that at this voltage, the expected measuring error of the output signal will be the least. For other operating voltages, the offset error will be increased by a changing power loss of the sensor electronics. If a re-calibration should become necessary later directly on the sensor, this can be done by means of a trimming potentiometer on the sensor board.

Remark: Occurring draft leads to a better carrying-off of dissipative power at the sensor. Thus temporally limited fluctuations might occur upon temperature measurement.

Technical Data

Measuring values		temperature
Output voltage	TRV	1x 0..10 V, min load 5 k Ω
Output Amp	TRA	1x 4..20 mA, max. load 500 Ω
Power supply	TRV	15..24 V = ($\pm 10\%$) or 24 V ~ ($\pm 10\%$)
	TRA	15..24 V = ($\pm 10\%$)
Power consumption	TRV	typ. 0,4 W (24 V =) 0,8 VA (24 V ~)
	TRA	max. 0,5 W (24 V =)
Measuring range temp	passive	-30..+80 °C
	TRV TRA	adjustable at the transducer: -50..+50 -20..+80 -15..+35 -10..+120 0..+50 0..+100 0..+160 0..+250 °C, default setting: -20..+80 °C
Accuracy temperature	TRV TRA	typ. $\pm 1\%$ of measuring range (typ. at 21 °C)
	passive	Pt100 / Pt1000: DIN class B
		Ni1000 / Ni1000TK5000: $\pm 0,4$ K (typ. at 0 °C) NTC10k: $\pm 0,22$ K (typ. at 25 °C)
Enclosure		enclosure USE-S, PC, pure white
Protection		IP65 according to EN60529
Cable entry		M16 for cable max. $\varnothing=8$ mm, removable
Connection electrical		removable plug-in terminal, max 2,5 mm ²
Sensor rod		copper, $\varnothing=4$ mm, mounting length: 400 mm, sensor neck stainless steel V4A $\varnothing=6$ mm
Ambient condition		-35..+70 °C, max 85% rH, short term condensation
Delivery content		incl. mounting clip enclosure USE-S pure white

Mounting Advices

The sensor can be mounted to the ventilation duct by means of the mounting clip.

Note: Please pay attention to the sensor rod while mounting and protect it from mechanical damage!

During the installation, observe that the bending radius of the sensor rod has to be no smaller than 35 mm.

Connection Plan and Configuration

The adjustment of the measuring ranges is made by changing the jumpers in a de-energized state. The output value of the new measuring range is available after 2 seconds.

TRA:
4..20 mA

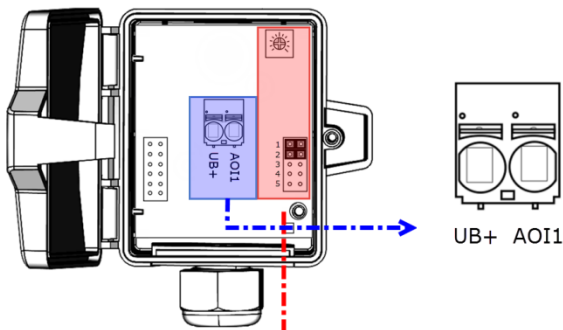

TRV:
0..10 V | 0..5 V

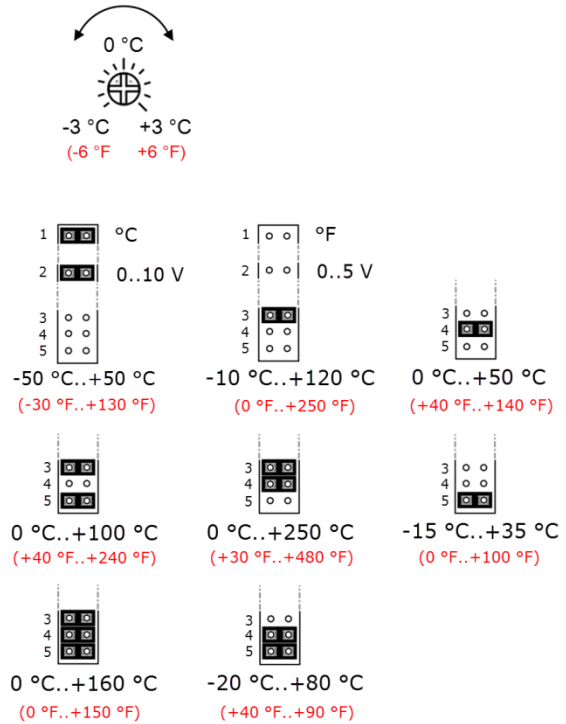
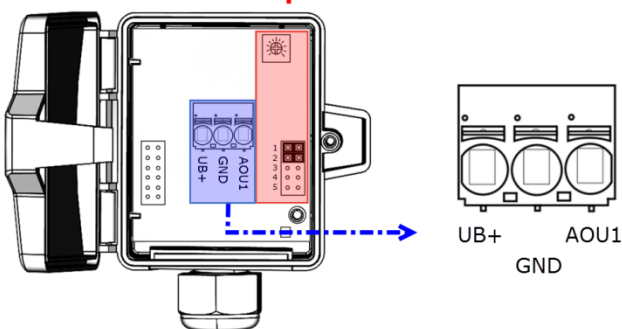

fig. (Measuring range and offset adjustment, default settings: -20 °C..+80 °C | 0 K)

Passiv

(NTC10k | Pt100 | Pt1000 | Ni1000 | Ni1000TK5000)

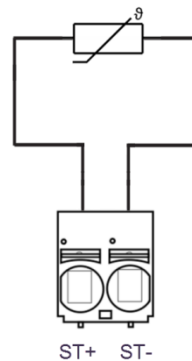
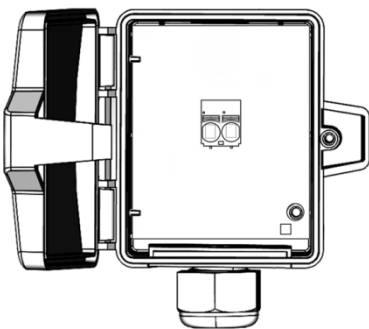
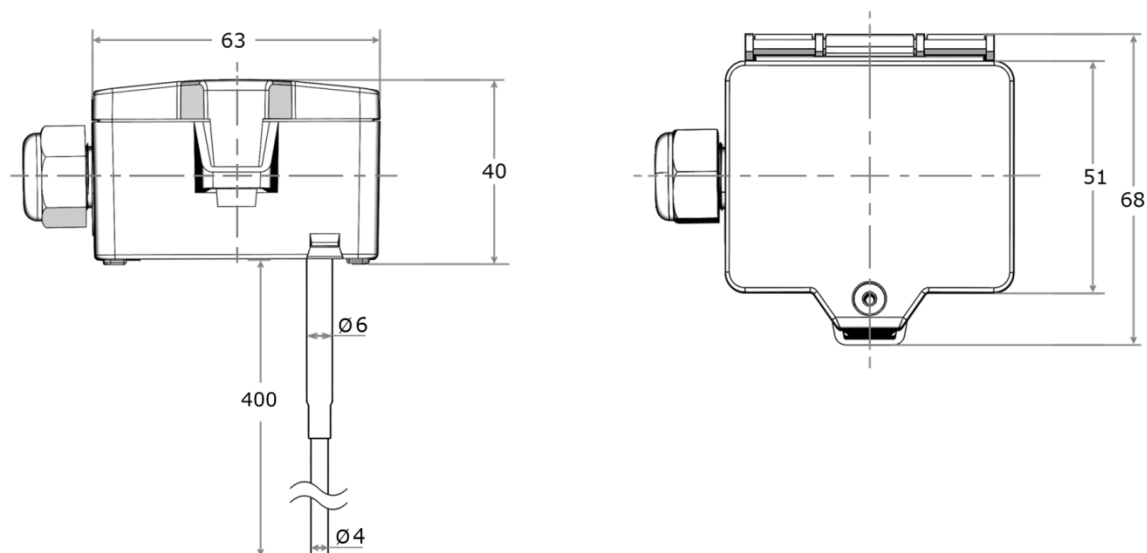

fig. (terminal assignment passive sensor)

Dimensions (mm)



Accessories (optional)

Mounting flange MF6 flexible (incl. inserts for $\varnothing=4$ | 6 | 7 mm)

Item No. 399098

Sealing inserts cable entry (packaging unit 10 pcs.)

\varnothing	3 mm	5 mm	7 mm	8 mm
Item No.	641036	641012	639248	641340