

# » RDF-IR (LCD) RS485 BACnet

Ceiling sensor surface temperature

**thermokon**<sup>®</sup>  
HOME OF SENSOR TECHNOLOGY

## Datasheet

Subject to technical alteration  
Issue date: 02/23/2021 • A110



Illustration similar

## » APPLICATION

Ceiling flush-mounted sensor for surface temperature measurement in room, office spaces and other workplaces. Using the infrared measuring principle, an averaged temperature over the circular detection range (optical detection range  $80 \pm 5^\circ$ ) is performed. If two IR sensors are used, the mean, minimum or maximum value of both temperature signals can be provided in addition to the individual temperatures of each sensor (configurable via Thermokon USEapp).

## » TYPES AVAILABLE

**Ceiling flush mount sensor with display temperature – active BUS**

RDF-IR (LCD) RS485 BACnet MS/TP

## » SECURITY ADVICE – CAUTION



The installation and assembly of the device should only be performed by authorized personnel.

The product should only be used for the intended application. Unauthorized modifications are prohibited! The product must not be used in relation with any equipment that in case of a failure may threaten, directly or indirectly, human health or life or result in danger to human beings, animals or assets. Ensure all power is disconnected before installing. Do not connect to live/operating equipment.

Please comply with

- Local laws, health & safety regulations, technical standards and regulations
- Condition of the device at the time of installation, to ensure safe installation
- This data sheet and installation manual

## » NOTES ON DISPOSAL



As a component of a large-scale fixed installation, Thermokon products are intended to be used permanently as part of a building or a structure at a pre-defined and dedicated location, hence the Waste Electrical and Electronic Act (WEEE) is not applicable. However, most of the products may contain valuable materials that should be recycled and not disposed of as domestic waste. Please note the relevant regulations for local disposal.

## » PRODUCT TESTING AND CERTIFICATION



### Declaration of conformity

The declaration of conformity of the products can be found on our website <https://www.thermokon.de/>.

## » USE ENCLOSURE WITH UV AND WEATHER RESISTANCE

After some time, outdoor mounted plastics can lose their color and quality. Therefore, all USE housings are made of special white polycarbonate (PC). The light-stable colorants and additives are used to achieve optimum protection of the polymer while maintaining color stability. The titanium dioxide used is specially developed for polycarbonate and offers excellent UV protection through the reflection of the entire light spectrum including the UV component by 340 nm. This effectively counteracts the otherwise occurring photochemical polymer degradation. The colors stay full for a long time without fading. The material is also resistant to cold and frost.

## » TECHNICAL DATA

Measuring values	surface temperature
Network technology	RS485 BACnet
Output voltage	1x/2x 0..10 V or 0..5 V (adjustable via jumper; live-zero configuration via Thermokon USEapp), min. load 10 kΩ
Power supply	15..35 V = or 19..29 V ~ SELV <i>With alternating voltage, the correct polarity must be ensured</i>
Power consumption	typ. 0,6 W (24 V =)   1,5 VA (24 V ~)
Output signal range temperature <small>*Scaling analogue output</small>	+40..+140 °F (default setting) selectable from 4 temperature ranges -40..+160 °F   +40..+140 °F   0..+200 °F   0..+100 °F adjustable at the transducer
Operating temperature range <small>* Max. permissible operating temp</small>	-4..+158 °F
Accuracy Temperature	±0,5 K (typ. at 70 °F within default measuring range) mounting height max. 23 ft., > 23 ft. ± 1,5 K
Sensor	PIR (passive infrared), optical aperture angle (50% sensitivity): 80 ±5° Emissivity = 1.0, other values on request
Display <small>(optional)</small>	LCD 1.14x1.38 in. with RGB backlight
Enclosure	enclosure USE-M, PC, pure white, LCD: cover pc transparent
Protection	IP30 according to EN 60529
Cable entry	M25 with fourfold cable entry for wire with max. Ø=0.28 in., removable
Connection electrical	removable plug-in terminal, max. 14 AWG, sensor wire length= 4.9 ft. (1,5 m) (default), max. 33 ft. (10 m), plug RJ45
Ambient condition	max. 85% rH short term condensation

When several BUS devices are supplied by one 24 V AC voltage supply, it is to be ensured that all "positive" operating voltage input terminals (+) of the field devices are connected and all "negative" operating voltage input terminals (-) (=reference potential) are connected (in-phase connection of field devices). In the case of reversed polarity at one field device, a supply voltage short-circuit would be caused by that device.

**The consequential short-circuit current flowing through this field may cause damage to it. Therefore, pay attention to correct wiring.**

**» CONFIGURATION**

The Thermokon bluetooth dongle with micro-USB is required for communication between USEapp and USE-M / USE L (Item No.: 668262). Commercial bluetooth dongles are not compatible.

Application-specific reconfiguration of the devices can be performed using the Thermokon USEapp. The configuration can be performed only when the device is powered.

The configuration-app and the app description can be found in the Google Play Store or in the Apple App Store.

**» APPLICATION NOTICE**

The housing cover must be completely closed in order to ensure the accuracy and reproducibility of the measured values during a test or service log via USEapp.

The Bluetooth dongle snaps into the socket easily. When removing, please fix the plug-in card (option PCB) so that it is not unintentionally pulled out.

The ceiling flush mounted sensor is installed in a 26 mm diameter hole.

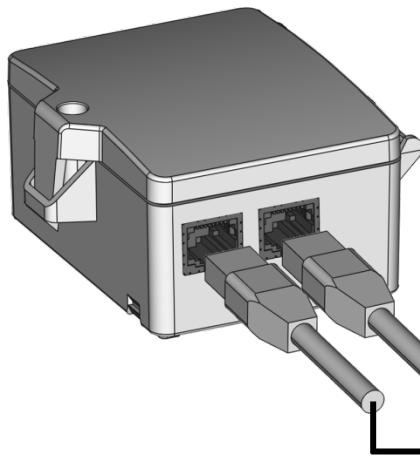
**» APPLICATION**

Two RJ45 sockets are integrated, instead of permanently connected cables. This allows 2 temperature sensors to be connected with a shielded RJ45 cable of up to 10 m in length. The user can independently extend the basic versions with one temperature sensor (RDF-IR V | RDF-IR A) with a second temperature sensor.

• Sensor 2 (Output temperature 2)

• Sensor 1 (Output temperature 1)

» **CONNECTION PLAN**

To change the output voltage range (default 0..10 V to 0..5 V) via jumper, the display must be removed from the board first. If the RS485 cable is looped through, connect both cable shields using the enclosed 2-pol. Connect terminal as shown.

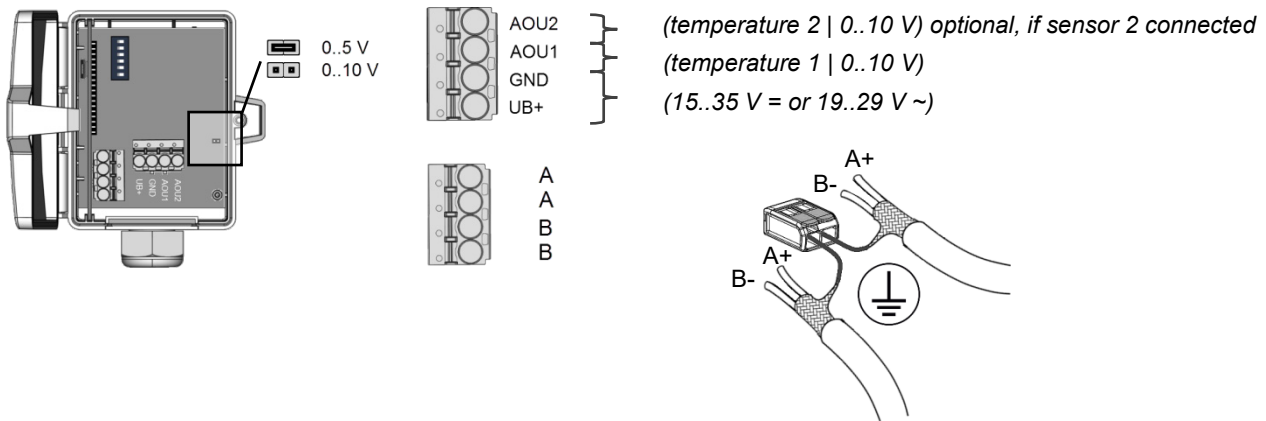

**Address block 1**

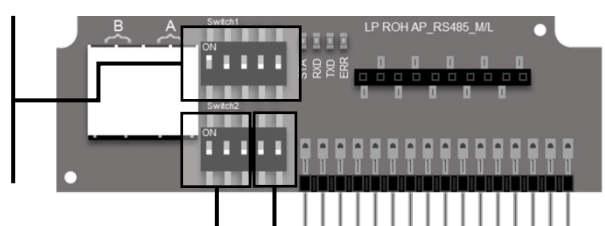
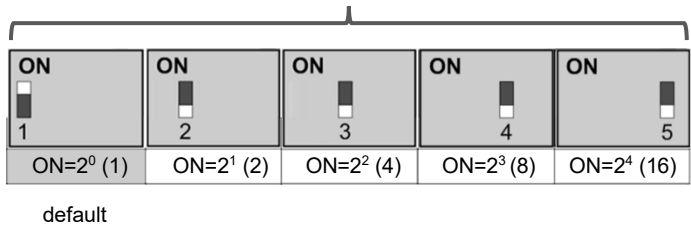

**Termination 120Ω**

**Baud rate**

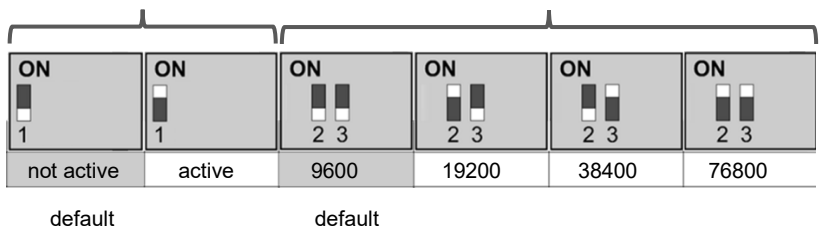

**Address block 2**

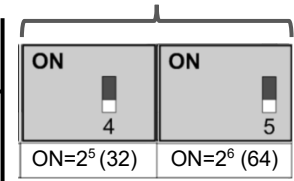

**Object AV-38 = 1 (Unit SI)**

Object	Access	Description	COV increment	Unit
AI-0	R	Temperature 1	0..+250 °C	°C
AI-12	R	Temperature 2	0..+250 °C	°C

**Object AV-38 = 2 (Unit Imperial)**

Object	Access	Description	COV increment	Unit
AI-0	R	Temperature 1	0..+480 °F	°F
AI-12	R	Temperature 2	0..+480 °F	°F

The BACnet address of the device is set binary coded in the range of 1 ... 127 via 7 dip-switches. (the address 0 is reserved and cannot be selected).



**BACnet Objects, PICS and BIBBs**  
USE-RS485 BACnet interface

A detailed description of the BACnet interface can be found at the following link:  
→ [Download](#)

» **DIP SWITCH CONFIGURATION**

**DIP 1..3**

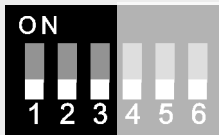

#0  
reserved

**Measuring range - DIP 4,5**

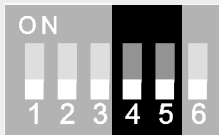

#0 (factory default)  
SI = 0..+50 °C  
IMP = +40..+140 °F



#8  
SI = -20..+80 °C  
IMP = 0..+200 °F

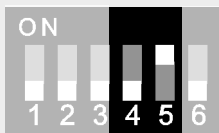

#16  
SI = -40..+60 °C  
IMP = -40..+160 °F

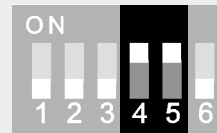

#24  
SI = -15..+35 °C  
IMP = 0..+100 °F

**System of units - DIP 6**

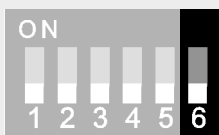

#0 (factory default)  
SI

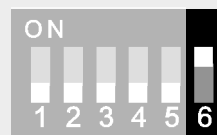

#32  
IMP

» **DIMENSIONS (IN.)**

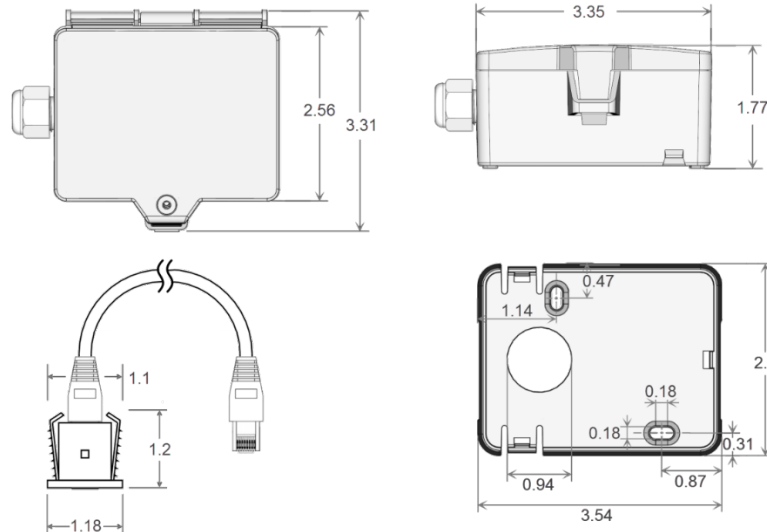

» **ACCESSORIES (INCLUDED IN DELIVERY)**

- Mounting base
- Mounting kit universal
- Cover screw + screw cover • 2 Rawlplugs • 2 Screws (countersunk head) • 2 Screws (rounded head)

Item No. 631228  
Item No. 698511

» **ACCESSORIES (OPTIONAL)**

- Bluetooth dongle
- Cable entry M25 USE white, sealing insert 4x Ø=0.28 in. (4 pcs)

Item No. 668262  
Item No. 641364