

# » LP+ CO2 (LCD) RS485 Modbus

Room pendulum sensor

**thermokon**<sup>®</sup>  
HOME OF SENSOR TECHNOLOGY

## Datasheet

Subject to technical alteration  
Issue date: 03.08.2020 • A111



*Image similar*

## » APPLICATION

Air quality sensor for measuring CO<sub>2</sub>, temperature and humidity in outdoor areas with 2 0..10 V output. LCD models with RGB background light have a transparent cover.

## » TYPES AVAILABLE

### Room pendulum sensor optional with display CO<sub>2</sub> + temp + optional rH – active BUS

LP+ CO<sub>2</sub> (LCD) Temp RS485 Modbus  
LP+ CO<sub>2</sub> (LCD) Temp\_rH RS485 Modbus

### Room pendulum sensor optional with display CO<sub>2</sub> + temp + optional rH and 2 digital inputs – active BUS

LP+ CO<sub>2</sub> (LCD) Temp RS485 Modbus 2IN  
LP+ CO<sub>2</sub> (LCD) Temp\_rH RS485 Modbus 2IN

## » SECURITY ADVICE – CAUTION



The installation and assembly of electrical equipment should only be performed by authorized personnel.

The product should only be used for the intended application. Unauthorised modifications are prohibited! The product must not be used in relation with any equipment that in case of a failure may threaten, directly or indirectly, human health or life or result in danger to human beings, animals or assets. Ensure all power is disconnected before installing. Do not connect to live/operating equipment.

Please comply with

- Local laws, health & safety regulations, technical standards and regulations
- Condition of the device at the time of installation, to ensure safe installation
- This data sheet and installation manual

## » NOTES ON DISPOSAL



As a component of a large-scale fixed installation, Thermokon products are intended to be used permanently as part of a building or a structure at a pre-defined and dedicated location, hence the Waste Electrical and Electronic Act (WEEE) is not applicable. However, most of the products may contain valuable materials that should be recycled and not disposed of as domestic waste. Please note the relevant regulations for local disposal.

## » GENERAL REMARKS CONCERNING SENSORS

Especially with regard to passive sensors in 2-wire conductor versions, the wire resistance of the supply wire has to be considered. If necessary the wire resistance has to be compensated by the follow-up electronics. Due to self-heating, the wire current affects the measurement accuracy, so it should not exceed 1 mA.

When using lengthy connection wires (depending on the cross section used) the measuring result might be falsified due to a voltage drop at the common GND-wire (caused by the voltage current and the line resistance). In this case, 2 GND-wires must be wired to the sensor - one for supply voltage and one for the measuring current.

Sensing devices with a transducer should always be operated in the middle of the measuring range to avoid deviations at the measuring end points. The ambient temperature of the transducer electronics should be kept constant. The transducers must be operated at a constant supply voltage ( $\pm 0,2$  V). When switching the supply voltage on/off, onsite power surges must be avoided.

## » BUILD-UP OF SELF-HEATING BY ELECTRICAL DISSIPATIVE POWER

Temperature sensors with electronic components always have a dissipative power, which affects the temperature measurement of the ambient air. The dissipation in active temperature sensors shows a linear increase with rising operating voltage. This dissipative power has to be considered when measuring temperature. In case of a fixed operating voltage ( $\pm 0,2$  V) this is normally done by adding or reducing a constant offset value. As Thermokon transducers work with a variable operating voltage, only one operating voltage can be taken into consideration, for reasons of production engineering. Transducers 0..10 V / 4..20 mA have a standard setting at an operating voltage of 24 V =. That means, that at this voltage, the expected measuring error of the output signal will be the least. For other operating voltages, the offset error will be increased by a changing power loss of the sensor electronics. If a re-calibration should become necessary later directly on the sensor, this can be done by means of the USEapp software and an optional Bluetooth interface.

**Remark: Occurring draft leads to a better carrying-off of dissipative power at the sensor. Thus temporally limited fluctuations might occur upon temperature measurement.**

## » INFORMATION ABOUT INDOOR AIR QUALITY CO<sub>2</sub>

EN 13779 defines several classes for indoor air quality:

Category	CO <sub>2</sub> content above the content in outdoor air in ppm		Description
	Typical range	Standard value	
IDA1	<400 ppm	350 ppm	Good indoor air quality
IDA2	400.. 600 ppm	500 ppm	Standard indoor air quality
IDA3	600..1.000 ppm	800 ppm	Moderate indoor air quality
IDA4	>1.000 ppm	1.200 ppm	Poor indoor air quality

## » INFORMATION ABOUT SELF-CALIBRATION FEATURE CO<sub>2</sub>

Virtually all gas sensors are subject to some sort of drift. The degree of drift is partially dependent on the use of quality components and good design. But even with good components and excellent design, a small amount of drift can still occur in the sensor that may ultimately result in the need for a sensor to be recalibrated.

The natural drift of the sensor is caused by:

- Dust/dirt • Aggressive chemicals absorbed inside chamber / optical elements • Corrosion inside chamber (high rh, condensation) • Temperature cycles causing mechanical stress • Electron/hole migration in the photo detector's semiconductor • Drift of photo amplifiers • External mechanical stress on chamber • Light source wear-off

Most of the effects listed above will be compensated by the automatic self-calibration of the sensor's dual channel technology. In contrast to commonly used ABC-Logic self-calibrating sensors with dual channel technology are suitable for all applications including those operating 24 hours, 7 days a week, for example hospitals.

However some effects cannot be compensated automatically and may result in a very gradual natural drift of a few ppm per month. This natural drift is not covered by Thermokon's 5-year warranty.

## » TECHNICAL DATA

Measuring values (type-dependent)	CO <sub>2</sub> , temperature + humidity (depending on the device)	
Output voltage	2x 0..10 V or 0..5 V, min. load 10 kΩ (live-zero configuration via Thermokon USEapp)	
Network technology	RS485 Modbus, RTU, half-duplex, baud rate 9.600, 19.200, 38.400 or 57600, parity: none (2 stopbits), even or odd (1 stopbit)	
Power supply	15..35 V = or 19..29 V ~ SELV <i>With alternating voltage, the correct polarity must be ensured</i>	
Power consumption	max. 2,3 W (24 V =)   max. 4,3 VA (24 V ~)	
Measuring range temp.	0..+50 °C (default setting), optionally configurable via Thermokon USEapp	
Measuring range humidity (type-dependent)	<b>Temp_rH</b> 0..100% rH non-condensing, optionally configurable via Thermokon USEapp (enthalpy, absolute humidity, dew point)	
Measuring range CO <sub>2</sub>	0..2000 ppm (default), 0..5000 ppm, optionally configurable via Thermokon USEapp	
Accuracy temperature (type-dependent)	<b>Temp   Temp_rH</b> ±0,5 K (typ. at 21 °C)	
Accuracy humidity (type-dependent)	<b>Temp_rH</b> ±2% between 10..90% rH (typ. at 21 °C)	
Accuracy CO <sub>2</sub>	±50 ppm +3% of reading (typ. at 21 °C, 50% rH)	
Calibration	self-calibration, Dual Channel	
Sensor	NDIR (non-dispersiv, infrared), sensor wire white 5m or 10 m, other lengths on request	
Inputs (optional)	<b>2IN</b> 2x input for NTC10k or floating contact	
Display (optional)	LCD 29x35 mm with RGB backlight	
Enclosure (type-dependent)	enclosure USE-L, PC, pure white, with removable cable entry	<b>with LCD (optional)</b> cover PC, transparent
Protection	IP65 according to EN 60529	
Cable entry	Flextherm M20, for wire Ø=4,5..9 mm, removable	
Connection electrical	<b>Mainboard</b> removable plug-in terminal, max. 2,5 mm <sup>2</sup>	<b>Plug-in card</b> removable plug-in terminal, max. 1,5 mm <sup>2</sup>
Ambient condition	0..+50 °C, max. 85% rH short term condensation	
Mounting	installation is also possible using mounting base	

When several BUS devices are supplied by one 24 V AC voltage supply, it is to be ensured that all "positive" operating voltage input terminals (+) of the field devices are connected with each other and all "negative" operating voltage input terminals (-) (=reference potential) are connected together (in-phase connection of field devices). In case of reversed polarity at one field device, a supply voltage short-circuit would be caused by that device. The consequential short-circuit current flowing through this field may cause damage to it.

Therefore, pay attention to correct wiring.

## » CONFIGURATION



The Thermokon bluetooth dongle with micro-USB is required for communication between USEapp and USE-M / USE L (Item No.: 668262). Commercial bluetooth dongles are not compatible.

Application-specific reconfiguration of the devices can be carried out using the Thermokon USEapp. The configuration is carried out in the voltage-supplied state.

The configuration-app and the app description can be found in the Google Play Store or in the Apple App Store.



» APPLICATION NOTICE



The housing cover must be completely closed in order to ensure the accuracy and reproducibility of the measured values during a test or service log via USEapp.

The Bluetooth dongle snaps into the socket easily. When removing, please fix the plug-in card (option PCB) so that it is not unintentionally pulled out.

» CONNECTION PLAN

To change the output voltage range (default 0..10 V to 0..5 V) via jumper, the display must be removed from the board first. Looped through power supply - valid from 03.08.2020 (20216).

LP+ CO2 LCD RS485 Modbus

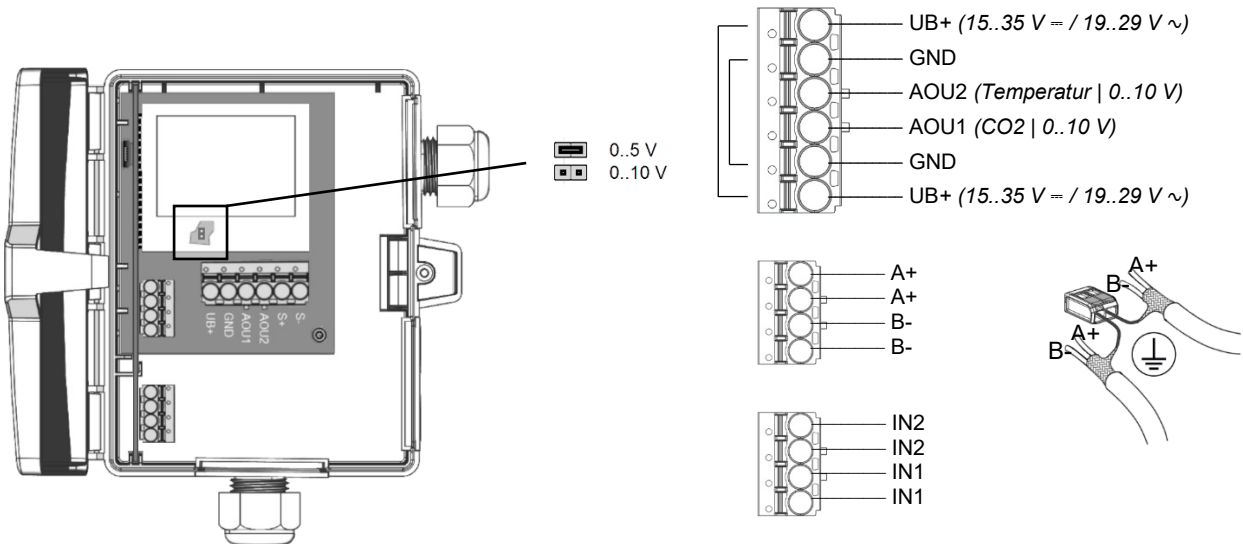

Dip switches, plug-in card

The modbus address of the device is set in the range of 1 ... 31 (binary encoded) using a 5-pole DIP switch. With address 0 via DIP, an extended address range (32..247) is available via USEapp.

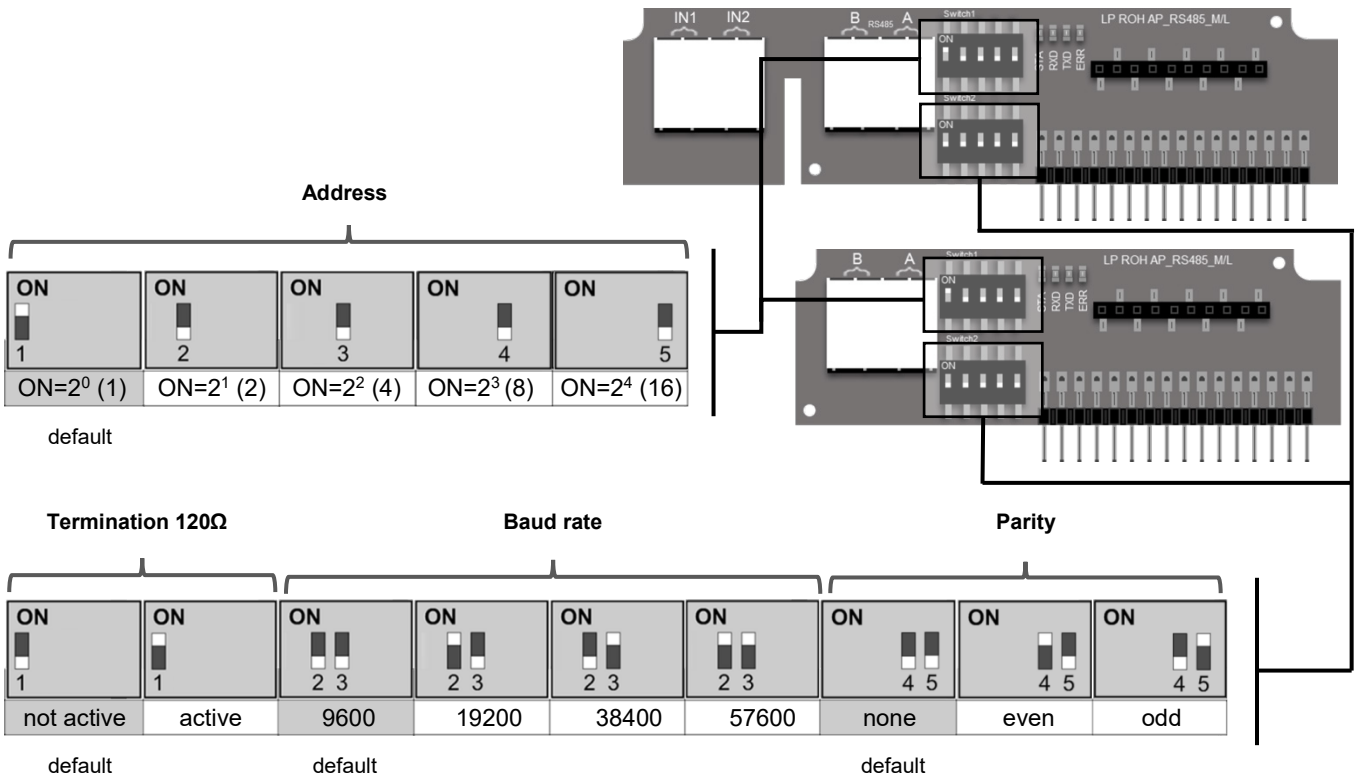

Address	Access	Description	Resolution / Unit	
1	R	relative humidity	0.1	%rF
5	R	CO2	1.0	ppm

**Register 400 = 1 (Unit SI)**

Address	Access	Description	Resolution / Unit		
0	R	Temperature	SI	0.1	°C
2	R	Absolute humidity	SI	0.01	g/m <sup>3</sup>
3	R	Enthalpy	SI	0.1	kJ/kg
4	R	Dew point	SI	0.1	°C

**Register 400 = 2 (Unit Imperial)**

Address	Access	Description	Resolution / Unit		
0	R	Temperature	Imperial	0.1	°F
2	R	Absolute humidity	Imperial	0.01	gr/ft <sup>3</sup>
3	R	Enthalpy	Imperial	0.1	BTU/lb
4	R	Dew point	Imperial	0.1	°F

**Optional (IN1 | IN2)**

NTC10k temperature sensors or floating contacts can be connected to the inputs (IN1 & IN2).

Address	Access	Description	Values	
92	R / s16	Input 1 – Switch contact	0	Contact open
93	R / s16	Input 2 – Switch contact	1	Contact closed

**Register 400 = 1 (Unit SI)**

Address	Access	Description	Resolution / Unit		
90	R / s16	Input 1 - Temperature NTC10k (beta value configurable, register address 490, default: 3864)	SI	0.1	°C
91	R / s16	Input 2 - Temperature NTC10k (beta value configurable, register address 491, default: 3864)	SI	0.1	°C

**Register 400 = 2 (Unit Imperial)**

Address	Access	Description	Resolution / Unit		
90	R / s16	Input 1 - Temperature NTC10k (beta value configurable, register address 490, default: 3864)	Imperial	0.1	°F
91	R / s16	Input 2 - Temperature NTC10k (beta value configurable, register address 491, default: 3864)	Imperial	0.1	°F

**Modbus addresses:**

USE-RS485 Modbus Interface

A detailed description of the Modbus addresses can be found under the following link:

→ [Download](#)

## » DIMENSIONS (MM)

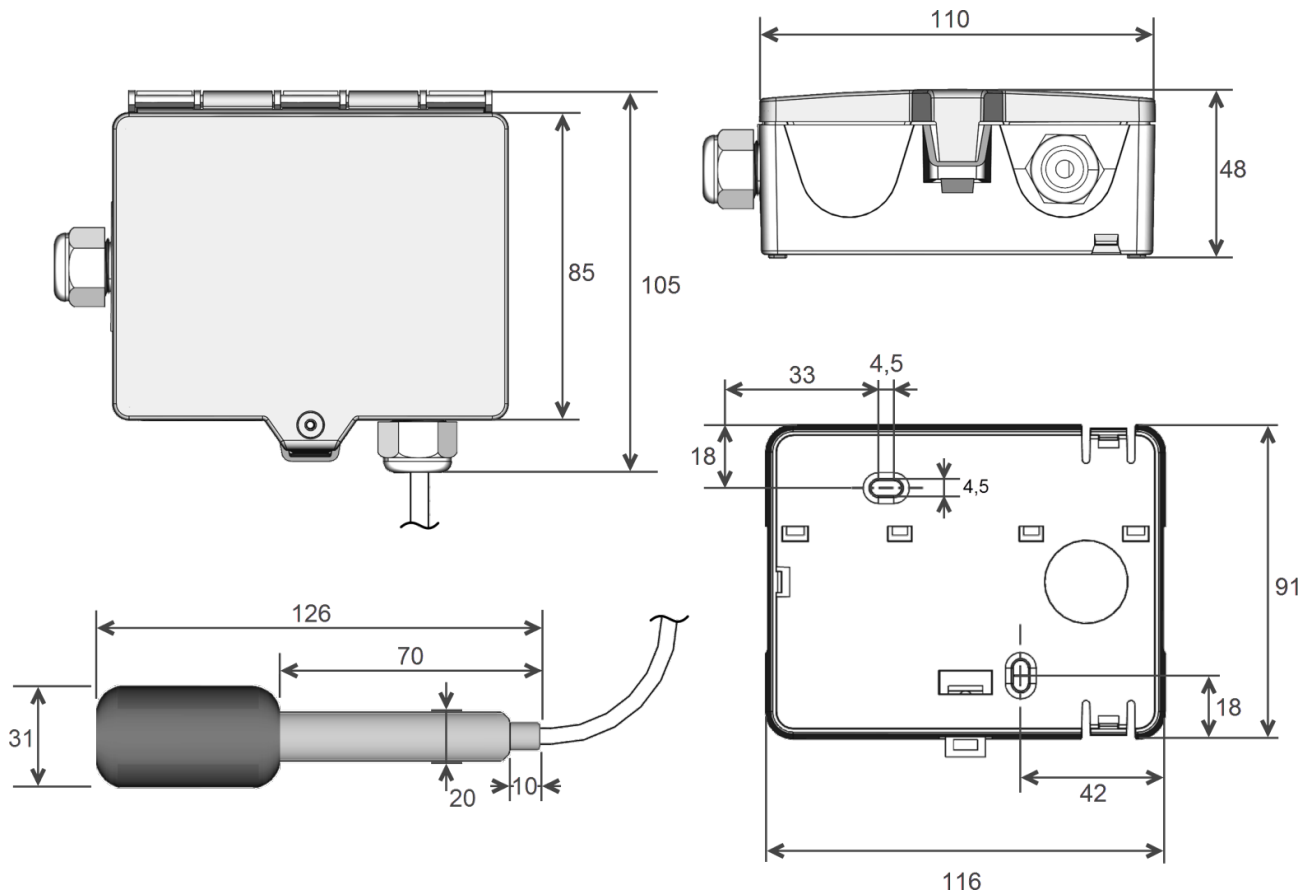

## » ACCESSORIES (INCLUDED IN DELIVERY)

Mounting base  
 Mounting kit universal  
 • Cover screw + screw cover • 2 Rawlplugs • 2 Screws (countersunk head) • 2 Screws (rounded head)

Item No. 631228  
 Item No. 698511

## » PRODUCT TESTING AND CERTIFICATION



### Declaration of conformity

The declaration of conformity of the products can be found on our website <https://www.thermokon.de/>.