

## » NOVOS 3 RS485 Modbus

Room sensor, optional with CO2 | VOC | Temperature | Humidity

**thermokon**<sup>®</sup>  
HOME OF SENSOR TECHNOLOGY

### Datasheet

Subject to technical alteration  
Issue date: 22.06.2020 • A110

novos



With design cover (left), standard design w/o design cover (right)

### » APPLICATION

The maintenance-free sensor creates the conditions for a pleasant indoor climate and well-being. Typical applications are schools, office buildings, hotels, cinemas or similar. The device is available with additional LED display (traffic light function) with color change function for displaying the measured values. The threshold values can be individually configured via the Thermokon NOVOSApp.

### » TYPES AVAILABLE

#### Room sensor – active RS485 Modbus

NOVOS 3 Temp RS485 Modbus

NOVOS 3 Temp\_rH RS485 Modbus

NOVOS 3 CO2 Temp RS485 Modbus

NOVOS 3 CO2 Temp\_rH RS485 Modbus

NOVOS 3 VOC Temp RS485 Modbus

NOVOS 3 VOC Temp\_rH RS485 Modbus

NOVOS 3 CO2 + VOC RS485 Modbus

NOVOS 3 CO2 + VOC Temp\_rH RS485 Modbus

Devices with CO2 optional with TLF (RGB-LED indicating air quality (traffic light function 'TLF'))

## » SECURITY ADVICE – CAUTION



The installation and assembly of electrical equipment should only be performed by authorized personnel.

The product should only be used for the intended application. Unauthorised modifications are prohibited! The product must not be used in relation with any equipment that in case of a failure may threaten, directly or indirectly, human health or life or result in danger to human beings, animals or assets. Ensure all power is disconnected before installing. Do not connect to live/operating equipment.

Please comply with

- Local laws, health & safety regulations, technical standards and regulations
- Condition of the device at the time of installation, to ensure safe installation
- This data sheet and installation manual

## » NOTES ON DISPOSAL



As a component of a large-scale fixed installation, Thermokon products are intended to be used permanently as part of a building or a structure at a pre-defined and dedicated location, hence the Waste Electrical and Electronic Act (WEEE) is not applicable. However, most of the products may contain valuable materials that should be recycled and not disposed of as domestic waste. Please note the relevant regulations for local disposal.

## » REMARKS TO ROOM SENSORS

### Location and Accuracy of Room Sensors

The room sensor should be mounted in a suitable location for measuring accurate room temperature. The accuracy of the temperature measurement also depends directly on the temperature dynamics of the wall. It is important, that the back plate is completely flush to the wall so that the circulation of air occurs through the vents in the cover. Otherwise, deviations in temperature measurement will occur due to uncontrolled air circulation. Also the temperature sensor should not be covered by furniture or similar devices. Mounting next to doors (due to draught) or windows (due to colder outside wall) should be avoided. The temperature dynamics of the wall will influence the temperature measurement. Various wall types (brick, concrete, dividing and hollow brickwork) all have different behaviours with regards to thermal variations.

### Surface and Flush Mounting

The temperature dynamics of the wall influence the measurement result of the sensor. Various wall types (brick, concrete, dividing and hollow brickwork) have different behaviours with regard to thermal variations. A solid concrete wall responds to thermal fluctuations within a room in a much slower way than a light-weight structure wall. Room temperature sensors installed in flush boxes have a longer response time to thermal variations. In extreme cases they detect the radiant heat of the wall even if the air temperature in the room is lower for example. The quicker the dynamics of the wall (temperature acceptance of the wall) or the longer the selected inquiry interval of the temperature sensor is the smaller the deviations limited in time are.

## » BUILD-UP OF SELF-HEATING BY ELECTRICAL DISSIPATIVE POWER

Temperature sensors with electronic components always have a dissipative power, which affects the temperature measurement of the ambient air. The dissipation in active temperature sensors shows a linear increase with rising operating voltage. This dissipative power has to be considered when measuring temperature. In case of a fixed operating voltage ( $\pm 0,2$  V) this is normally done by adding or reducing a constant offset value. As Thermokon transducers work with a variable operating voltage, only one operating voltage can be taken into consideration, for reasons of production engineering. Transducers 0..10 V / 4..20 mA have a standard setting at an operating voltage of 24 V =. That means, that at this voltage, the expected measuring error of the output signal will be the least. For other operating voltages, the offset error will be increased by a changing power loss of the sensor electronics. If a re-calibration should become necessary later directly on the sensor, this can be done by means of the NOVOSapp software and an optional Bluetooth interface. (additionally with sensors with BUS interface via an appropriate software variable).

**Remark: Occurring draft leads to a better carrying-off of dissipative power at the sensor. Thus temporally limited fluctuations might occur upon temperature measurement.**

## » APPLICATION NOTICE FOR HUMIDITY SENSORS

Refrain from touching the sensitive humidity sensor/element. Touching the sensitive surface will void warranty.

For standard environmental conditions re-calibration is recommended once a year to maintain the specified accuracy.

When exposed to high ambient temperature and/or high levels of humidity or presence of aggressive gases (i.e. chlorine, ozone, ammonia) the sensor element may be affected and re-calibration may be required sooner than specified. Re-calibration and deterioration of the humidity sensor due to environmental conditions are not subject of the general warranty.

» **INFORMATION ABOUT SELF-CALIBRATION FEATURE CO2**

Virtually all gas sensors are subject to some sort of drift. The degree of drift is partially dependent on the use of quality components and good design. But even with good components and excellent design, a small amount of drift can still occur in the sensor that may ultimately result in the need for a sensor to be recalibrated. The natural drift of the sensor is caused by:

- Dust/dirt • Aggressive chemicals absorbed inside chamber / optical elements • Corrosion inside chamber (high rh, condensation) • Temperature cycles causing mechanical stress • Electron/hole migration in the photo detector’s semiconductor • Drift of photo amplifiers • External mechanical stress on chamber • Light source wear-off

Most of the effects listed above will be compensated by the automatic self-calibration of the sensor’s dual channel technology. In contrast to commonly used ABC-Logic self-calibrating sensors with dual channel technology are suitable for all applications including those operating 24 hours, 7 days a week, for example hospitals. However some effects cannot be compensated automatically and may result in a very gradual natural drift of a few ppm per month. This natural drift is not covered by Thermokon’s 5-year warranty.

» **INFORMATION ABOUT INDOOR AIR QUALITY CO2**

EN 13779 defines several classes for indoor air quality:

Category	CO <sub>2</sub> content above the content in outdoor air in ppm		Description
	Typical range	Standard value	
IDA1	<400 ppm	350 ppm	Good indoor air quality
IDA2	400.. 600 ppm	500 ppm	Standard indoor air quality
IDA3	600..1.000 ppm	800 ppm	Moderate indoor air quality
IDA4	>1.000 ppm	1.200 ppm	Poor indoor air quality

» **APPLICATION NOTICE FOR AIR QUALITY SENSORS VOC**

Unlike CO<sub>2</sub> sensors, which specifically measure CO<sub>2</sub>, mixed gas sensors detect a wide range of gases. The sensor signal does not indicate the type of gas or it’s concentration in ppm. Mixed gas sensors detect gases and vapours consisting of carbohydrates, or more generally gases that can be oxidised (burnt): Odours, perfume, cleaning fluid scent, tobacco smoke, new materials fumigations (furniture, carpets, paint, glue ...).

Unlike CO<sub>2</sub>, which humans cannot sense, the amount of odours (VOC) indicates the level of air quality. VOC sensors have proven their value in a multitude of applications for many years.

**Measuring principle:**

A heated tin dioxide semiconductor sensor burns (oxidizes) organic molecules that come into contact with it, thereby changing the resistance of the semiconductor. The change in resistance is characteristic for the type and concentration of the molecules. Gas mixtures such as air produce a mixed signal that can not be deduced from individual components. CO<sub>2</sub> can not be detected because it can not be burned.

**Refrain from touching the sensor’s element sensitive surface. Touching the sensitive surface element will void warranty.**

» **INFORMATION ABOUT CALIBRATION VOC**

Similar to a catalyst, the sensitivity of the sensor decreases over time. The VOC sensor compensates for this decrease in sensitivity through regular auto-calibration.

The measured values are recorded over a period of 24 hours. The lowest value within this period is used as the reference value ("new zero level") for clean, fresh air. Measured thereafter, lower readings result in an immediate adjustment of the reference value.

» **PRODUCT TESTING AND CERTIFICATION**



**Declaration of conformity**

The declaration of conformity of the products can be found on our website <https://www.thermokon.de/>.

## » TECHNICAL DATA

Measuring values (optional)	temperature   humidity   CO2   VOC
Network technology	RS485 Modbus, RTU, half-duplex, baud rate 9.600, 19.200, 38.400 or 57600, parity: none (2 stopbits), even or odd (1 stopbit)
Power supply	15..35 V = (or 19..29 V ~)* SELV
Power consumption	typ. 0,4 W (24 V =)   0,8 VA (24 V ~)
Inputs	1x input for floating contact
Enclosure	PC V0, pure white, design cover (optional)
Protection	IP20 according to DIN EN 60529
Cable entry	rear entry, breaking points bottom, drill mark top
Connection electrical	tool-free mountable spring terminal, max. 1,5 mm <sup>2</sup>
Ambient condition	-20..+70 °C, max. 85% non-condensing, with CO2 sensor operating temperature range 0..+50 °C
Mounting	surface mounted on flush-mounting box (Ø=60 mm) or to be mounted flat onto the surface using screws, base part can be mounted and wired separately
Notes	for configuration an optional programming dongle (Bluetooth) is available (refer to accessories)

## » Temperature

Measuring range temp	-20..+70 °C
Accuracy temperature	±0,5K (typ. at 21 °C)

## » Humidity

Measuring range humidity (optional configurable)	<b>relative humidity</b> (default) 0..100% rH	<b>Enthalpy</b> 0..85 KJ/kg	<b>absolute humidity</b> 0..50   0..80 g/m <sup>3</sup> ,	<b>dew point</b> 0..+50   -20..+80 °C,
	configurable via Thermokon NOVOSapp or BUS			
Accuracy humidity	±2% between 10..90% rH (typ. at 21 °C)			

## » CO2

Measuring range CO2	0..2000 ppm   0..5000 ppm (configurable via Thermokon NOVOSapp or BUS)
Accuracy CO2	±50 ppm +3 % of reading (typ. at 21 °C, 50% rH, 1015 hPa)
Calibration	self-calibration dual channel
Sensor	NDIR (non-dispersive, infrared)
Display (optional)	RGB-LED indicating air quality (traffic light function 'TLF')

## » VOC

Measuring range VOC	0..100 %
Calibration	self-calibration
Sensor	VOC sensor (heated metal oxide semiconductor)

## \*Power supply

When several BUS devices are supplied by one 24 V AC voltage supply, it is to be ensured that all "positive" operating voltage input terminals (+) of the field devices are connected with each other and all "negative" operating voltage input terminals (-) (=reference potential) are connected together (in-phase connection of field devices).

In case of reversed polarity at one field device, a supply voltage short-circuit would be caused by that device. The consequential short-circuit current flowing through this field may cause damage to it.

**Therefore, pay attention to correct wiring.**

**» MOUNTING ADVICES**

Please make sure that the device is de-energized if you want to install it!

The installation can be performed on the flat wall surface or on a flush-mounted box. A representative place should be selected. Sunshine and draft, e.g. in the installation tube should be avoided, so that the measurement result is not falsified. Seal the end of the installation tube.

- For wiring, the upper part of the device must be removed from the base plate. Base plate and upper part are detachably connected to each other by means of locking lugs.
- The mounting of the base plate on the flat wall surface is done with rawplugs and screws.
- Finally, the device is attached to the base plate and fixed with the screw.

**Housing open / close**

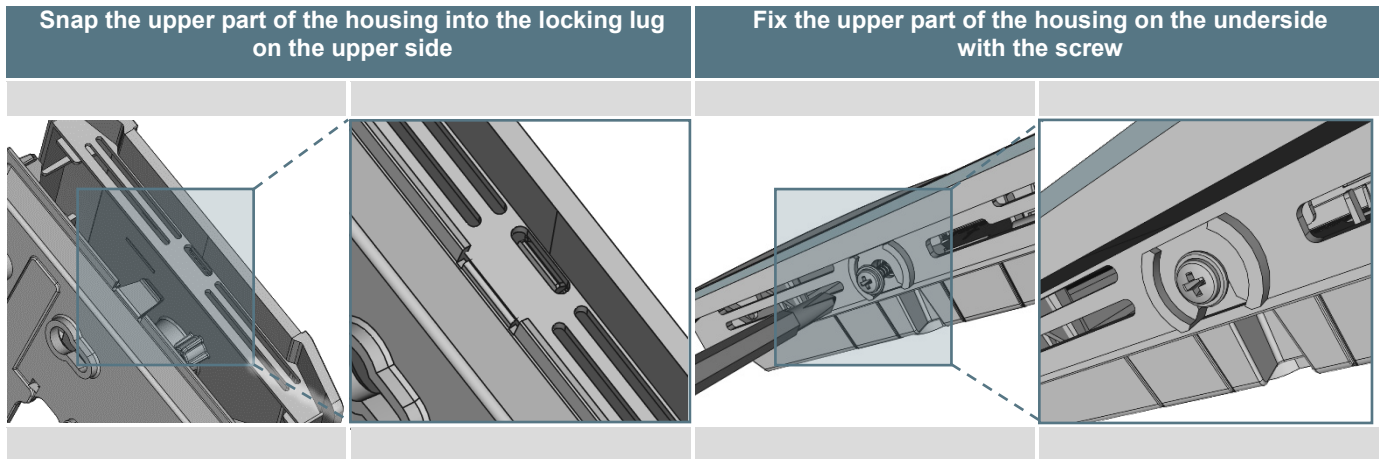

**Cable entry**

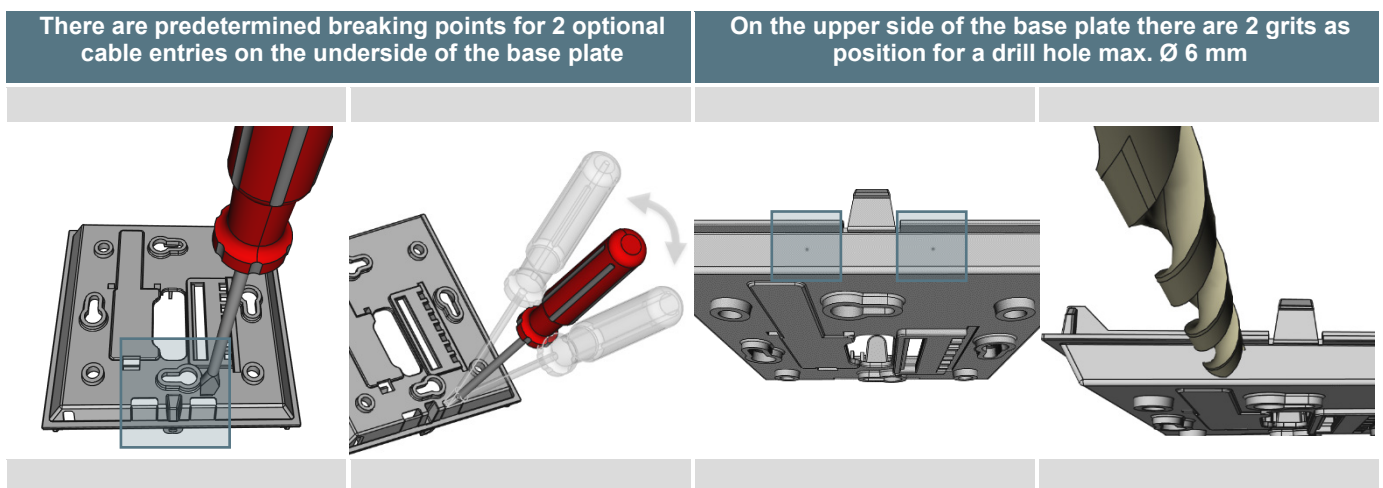

When using a drill, you should absolutely ensure that the base plate is firmly clamped. Before drilling, the pressure must be reduced and carefully drilled. A sudden break-through of the drill bit can be the result.

» CONFIGURATION



The Thermokon bluetooth dongle with micro-USB is required for communication between NOVOSapp and NOVOS products (Item No.: 668262). Commercial bluetooth dongles are not compatible.



Application-specific reconfiguration of the devices can be performed using the Thermokon NOVOSapp. The configuration performed in voltage-supplied state.



The configuration-app and the app description can be found in the Google Play Store or in the Apple App Store.

On the bottom there is the micro USB port for the Bluetooth dongle	If the Bluetooth dongle is connected to the device, the device can be configured via Bluetooth with the NOVOSapp
--	--

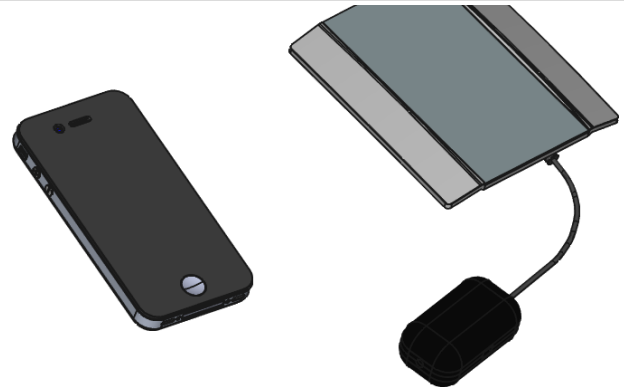
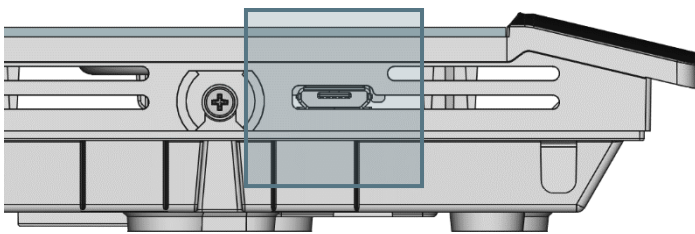

» CONNECTION PLAN

Room sensor – active RS485 Modbus

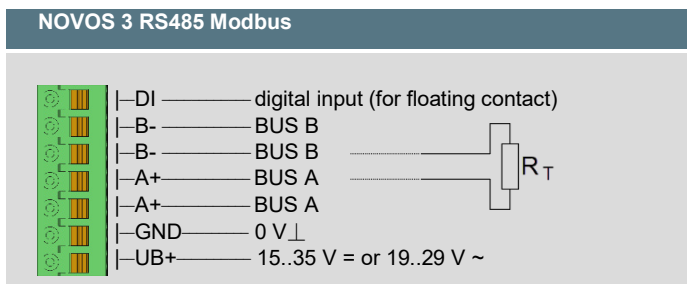

With alternating voltage, the correct polarity must be ensured! Please note the technical data.

Don't forget the BUS termination (120 Ω) at the last device of the line! (Not included in delivery)

» TLF – TRAFFIC LIGHT FUNCTION (OPTIONAL)

The traffic light function can be implemented with any available measured variable. Different colours can be assigned for up to 5 different measuring ranges.

Example: CO2 TLF

The LED visualizes the air quality value (Thresholds and colors optionally configurable via Thermokon NOVOSapp or BUS).

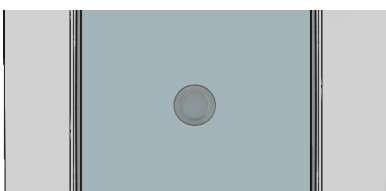

CO2 (Factory default)	Behavior of the LED
0..750 ppm	LCD lights up in green
751..1250 ppm	LCD lights up in yellow
1251..2000 ppm	LCD lights up in red

» **DIP-SWITCH-SETTINGS**

The modbus address of the device is set in the range of 1 ... 63 (binary encoded) using a 6-pole DIP switch. With address 0 via DIP, an extended address range (64..247) is available via NOVOSapp.

**Modbus-Address - DIP 1..6 (binary coded)**

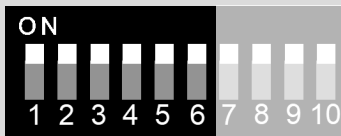

Dip switch	1 = on	2 = on	3 = on	4 = on	5 = on	6 = on
Value	2 <sup>0</sup> (1)	2 <sup>1</sup> (2)	2 <sup>2</sup> (4)	2 <sup>3</sup> (8)	2 <sup>4</sup> (16)	2 <sup>5</sup> (32)

factory default, address 63

**Baud rate - DIP 7 & 8**

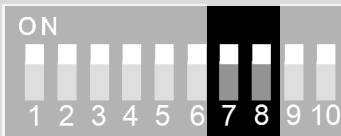

7	8	Baud rate
off	off	9600
on	off	19200
off	on	38400
on	on	57600 (factory default)

**Parity / Stop bits - DIP 9 & 10**

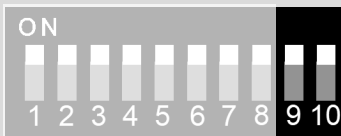

9	10	Parity
off	off	None – 2-Stop bits
on	off	Even – 1 Stopbit
off	on	Odd – 1 Stop bit
on	on	None – 1-Stop bit (factory default)

Address	Access	Description	Scaling / Unit	
501	R	<b>relative humidity</b> 850 = 85,0 %rH	0.1	%rF
505	R	CO2	1.0	ppm
506	R	VOC	0.1	%
507	R	CO2 / VOC MIX		
514	R	<b>Status digital input</b> open = 0 closed = 1		

**Register 1100 = 1 (Unit SI)**

Address	Access	Description	Scaling / Unit		
500	R	<b>Temperature</b> 210 = 21,0 °C	SI	0.1	°C
502	R	<b>Absolute humidity</b> 1500 = 15,00 g/m <sup>3</sup>	SI	0.01	g/m <sup>3</sup>
503	R	<b>Enthalpy</b> 550 = 55,0 kJ/m <sup>3</sup>	SI	0.1	kJ/kg
504	R	<b>Dew point</b> 180 = 18,0 °C	SI	0.1	°C

**Register 1100 = 2 (Unit Imperial)**

Address	Access	Description	Scaling / Unit		
500	R	<b>Temperature</b> 700 = 70,0 °F	Imperial	0.1	°F
502	R	<b>absolute humidity</b> 4200 = 4,2 gr/ft <sup>3</sup>	Imperial	0.01	gr/ft <sup>3</sup>
503	R	<b>Enthalpy</b> 240 = 24,0 BTU/lb	Imperial	0.1	BTU/lb
504	R	<b>dew point</b> 600 = 60,0 °F	Imperial	0.1	°F



**Modbus addresses:**  
NOVOS-RS485 Modbus Interface

A detailed description of the Modbus addresses can be found under the following link:

→ [Download](#)

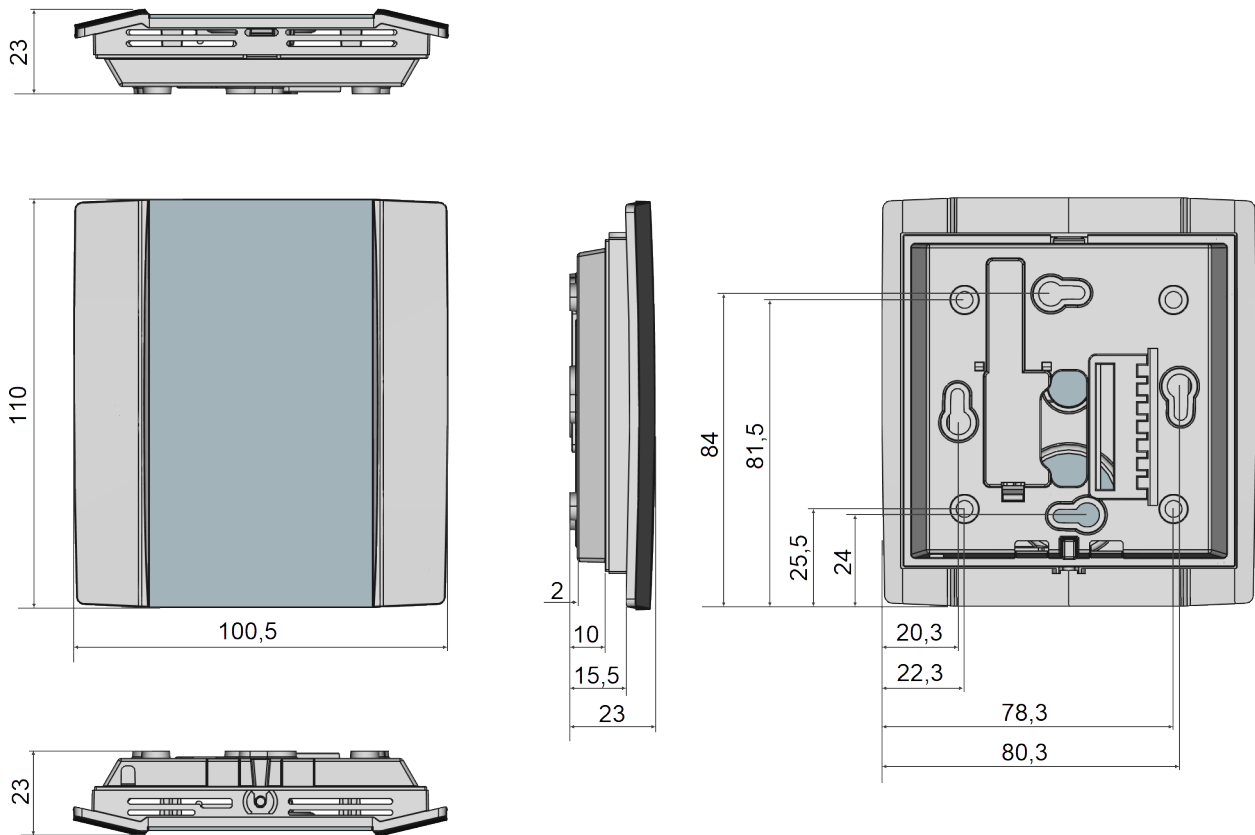
**» DIMENSIONS (MM)****» ACCESSORIES (OPTIONAL)**

Rawplugs and screws (2 pcs. each)  
 Frame for surface mounting NOVOS 3  
 Bluetooth dongle  
 Converter RS485 Modbus-USB incl. Driver CD  
 PSU-UP24 – flush mount power supply 24 V (AC Input: 100..240 V ~ | DC Output 24 V = 0,5 A)

Item No. 102209  
 Item No. 111584  
 Item No. 668262  
 Item No. 668293  
 Item No. 645737