

General notes

The valid "General Conditions for the Supply of Products and Services of the Electrical and Electronics Industry" (ZVEI conditions) including supplementary clause "Extended Retention of Title" apply as the exclusive General Terms and Conditions.

The following points must also be complied with:

- These instructions must be read before installation and putting into operation and all instructions contained therein must be observed!
- Devices must only be connected to safety extra-low voltage. Use shielded cables to avoid damage to the device and faults (e.g. resulting from voltage induction); avoid parallel routing with live lines and comply with the EMC directives.
- This device must be used for its intended purpose only. Respective safety regulations issued by the VDE, the states, their control authorities, the TÜV and the local energy supply company must be observed. The purchaser must ensure that the relevant building and safety regulations are complied with, and must avoid hazards of all kinds.
- No warranties or liabilities will be assumed for defects and damage arising from improper use of this device.
- Consequential damage caused by a fault in this device is excluded from warranty or liability.
- The devices must be installed by authorised specialists only.
- The technical data and connecting conditions of the mounting and operating instructions delivered together with the device are exclusively valid. Deviations from the catalogue representation are not explicitly mentioned and are possible in terms of technical progress and continuous improvement of our products.
- In case of any modifications made to the devices by the user, all warranty claims are forfeited.
- This device must not be installed close to heat sources (e.g. radiators) or be exposed to their heat flow. Direct solar irradiation or heat irradiation by similar sources (powerful lamps, halogen spotlights) must be avoided.
- Operating this device close to other devices that do not comply with EMC directives may influence functionality.
- This device must neither be used for monitoring applications, which solely serve the purpose of protecting people against hazards or injury, nor as an emergency stop switch for systems or machinery, nor for other similar safety-relevant purposes.
- Dimensions of housings or housing accessories may show slight tolerances on the specifications provided in these instructions.
- It is not permitted to modify these documents.
- In case of complaints, only complete units returned in original packing will be accepted.

Notes

- The voltage output is short-circuit proof. Applying overvoltage will destroy this device.
- The current output is an active output (3-wire technology), not a real 2-wire transmitter.
- In case of contamination, we recommend cleaning and recalibration in the factory.
- The working range of the device is 10...95 % relative humidity or 0...50 °C. Incorrect measurements or higher deviations occur outside the working range.
- The device performs an automatic calibration at an interval of 7 days. To ensure this function, the device must be supplied with fresh air (CO₂ content 300...400 ppm) for at least 10 minutes in a period of 7 days.
- If this device is operated beyond the specified range, all warranty claims are forfeited.

ATTENTION!

The minimum CO₂ concentration of outdoor air is approx. 350 ppm (output voltage= 1.75 V) in green areas with little industry, and approx. 600 ppm (output voltage= 3.0 V) in industrial regions. A self-test of the sensor is initialised by negative pressure/positive pressure. During the self-test, the output voltage (CO₂ output) of the device is approx. 0.2 volts. Gas exchange in the sensor element happens by diffusion. Depending on the change in concentration and the flow velocity of the air in the sensor environment, the reaction of the device to the change in concentration may be delayed.

Mounting and operating instructions

CONS^{ENS}

CO₂ pendulum meter

with voltage output and current output (active)

C-RPF-CO2-UI

Options/designs:

Relay (potential-free changeover contact)

Display

Display + relay

C-RPF-CO2-UIR

C-RPF-CO2-UID

C-RPF-CO2-UIRD

The room pendulum meter RPF-CO₂-UI detects the CO₂ concentration of the ambient air and converts it into the standard signals 0...10 V and 4...20 mA. There are 3 output scalings to choose from (0...2,000 ppm, 0...5,000 ppm and 0...10,000 ppm), which are set by DIP switches. The devices can be supplied with customised special ranges from 1,000 ppm to 50,000 ppm.

A potential-free changeover contact and/or a backlit display are optionally available. The switching threshold of the changeover contact is set by a 270° adjustment knob and always represents the selected scaling. The display content can be rotated by menu in 90° steps (installation position is unrestricted); measured value, set switching threshold, switching threshold and MIN/MAX of the selected interval (1 h / 6 h / 12 h or 24 h) can be shown. When the Display option is selected, the hinged cover housing BC" L90 W80 H47 mm (without probe attachments, cable glands, etc.) is used.

Symbol photo



Areas of application include: ventilation and air conditioning technology, ventilation monitoring, filter monitoring, level measurement.

The NDIR-based CO₂ sensor used is characterised by high accuracy, long-term stability and reliability; auto-calibration can be activated via DIP switch (default setting). In addition, it is possible to calibrate the system manually to 400 ppm by pressing a button.

These instructions must be read before installation and putting into operation and all instructions contained therein must be observed!

ConSens GmbH, Tel.: +49 (0)3677 4687 0
W.-v.-Siemens-Str. 14 Fax: +49 (0)3677 4687 77
98693 Ilmenau, Germany

Internet: www.consens-electronic.de
Contact: info@consens-electronic.de

Technical data:

Electrical connection: screw terminals, max. 1.5 mm²
 Operating voltage: 24 V AC/DC, half-wave rectifier, read the instructions!
 Current consumption: Ø 100 mA, peak current up to 300 mA
 Output 1 CO₂ content: 0...10 V depending on scaling
 Output 2 CO₂ content: 4...20 mA depending on scaling
 Alarm output, optional: potential-free changeover contact, max. 48 V, 1 A
 Display, optional: LCD display 128 x 64 pixels, backlight On/Off/Auto

Sensor, measuring ranges / deviation

CO₂ sensor element: NDIR sensor
 CO₂ measuring range: 0...10,000 ppm
 Selectable scalings: 0...2,000 ppm / 0...5,000 ppm / 0...10,000 ppm
 CO₂ measurement accuracy: ± 75 ppm ± 5 % measured value until 5,000 ppm, otherwise ± 100 ppm ± 5 % measured value
 @ 20 °C, 45 % RH, 1,013 mbar, auto-calibration activated
 Pressure dependence: ± 0.16 % / hPa based on standard pressure
 Temperature dependence: ± 5 ppm / K, based on 20 °C
 Long-term stability: ± 1 % final value / year
 Warm-up time: <10 min
 Response time: < 5 min
 Gas exchange: by diffusion

Connection conditions

Ambient temperature: 0...+50 °C
 Work area RH: 10...95 %, non-precipitating air free of harmful substances
 Storage temperature: -20...+50 °C
 Turn-on/warm-up time: 20 minutes

Miscellaneous

Sensor protection: in pendulum housing, sinter filter
 Housing: Tyr 2 plastic, UV-resistant, quick-locking screws
 Housing dimensions: L126 W90 H50 mm (without probe attachments, cable glands, etc.)
 Pendulum: Ø 25 x 100 mm, 2 m PVC cable
 Housing/probe protection type: IP 65/30
 Protection class: III
 Scope of delivery: operating instructions, device, transport box
 Standards: CE, RoHS

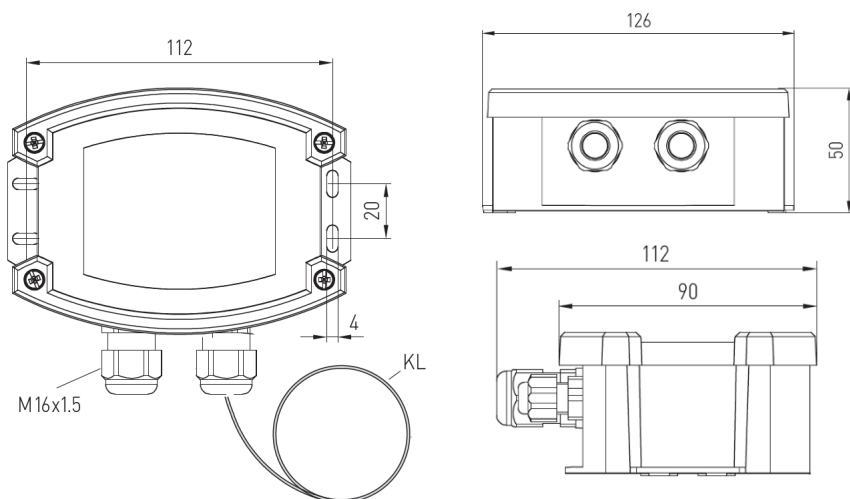

For operating voltage reverse polarity protection, a half-wave rectifier or reverse polarity protection diode is integrated in this device version. This internal half-wave rectifier also allows operation with AC supply voltage. The output signal must be tapped by a measuring instrument. Here, output voltage is measured against zero potential (0 V) of the input voltage! If this device is operated with DC supply voltage, the operating voltage input UB+ for 15...36 V DC supply and UB- or GND as the earth cable must be used!

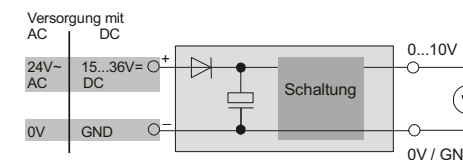

If several devices are supplied by one 24 V AC voltage supply, it must be ensured that all "positive" operating voltage input terminals (+) of the field devices are connected with each other and all "negative" operating voltage input terminals (- = reference potential) are connected with each other (in-phase connection of field devices). All outputs of field devices must be referenced to the same potential!

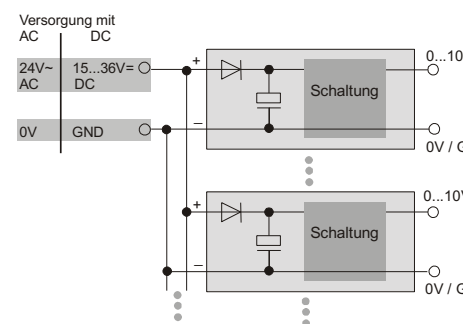

In case of reversed polarity of the supply voltage at one field device, a supply voltage short-circuit would be caused by that device. The resulting short-circuit current flowing through this field device may cause damage to it.

Therefore, pay attention to correct wiring!

Automatic calibration of carbon dioxide measurement (default)

The device performs an automatic calibration at an interval of 7 days. To ensure this function, the device must be supplied with fresh air (CO₂ content of the air approx. 350...400 ppm) for at least 10 minutes in a period of approx. 7 days (interval). For this self-calibration, the device stores device-internally the CO₂ content minimum value measured during a period of 7 days. After 7 days, this minimum value is normalised to 400 ppm CO₂ and the output signal is corrected accordingly. The maximum correction is limited to ½ of the determined difference to 400 ppm. To deactivate the function, set the DIP switch "auto CO₂" to OFF.

Manual calibration of the carbon dioxide measurement (by button)

Manual calibration can be started independently of the "auto CO₂" DIP switch position by pressing the button. After connecting the device, ensure that it is operated continuously for at least 10 minutes with fresh air (CO₂ content of 350...400 ppm). Manual calibration of the output signal to 2.00 V = 400 ppm = zero point is started by pressing the "calib. CO₂" button (press for approx. 5 seconds; LED changes from continuous to flashing). Preparation for calibration is signalled by the flashing LED. The output is then automatically set to 2.00 V at the current ambient conditions. During this phase, the LED is continuously activated. After successful calibration, the LED is deactivated again and the device switches to measuring mode.

C-RPF-CO2-UI, C-RPF-CO2-UID

| Supply | AC | DC |
|------------------------|-----------|--------------|
| → 1 | 24 V~ | 15...36 V DC |
| → 2 | 0 V | GND |
| Output | | |
| 3 → (CO ₂) | 0...10 V | 0...10 V |
| 4 → (CO ₂) | 4...20 mA | 4...20 mA |

C-RPF-CO2-UIR, C-RPF-CO2-UIRD

| Supply | AC | DC |
|------------------------|-------------|--------------|
| → 1 | 24 V~ | 15...36 V DC |
| → 2 | 0 V | GND |
| Output | | |
| 3 → (CO ₂) | 0...10 V | 0...10 V |
| 4 → (CO ₂) | 4...20 mA | 4...20 mA |
| 6 / 7 / 8 → | NC / C / NO | NC / C / NO |