



GDI1- Series (CO2)

**Duct Air Quality (CO2)
with Active Output**

The GDI1-Series (CO2) is designed to measure air quality in air ducts

of heating, ventilation and air conditioning systems

The air quality is measured based on CO2 levels (CO2 = Carbon dioxide)

The sensor operates with low power supply (SELV)

The air quality sensor output is active



Use

Compatible with all common HVAC DDC and Analog Controls systems, with/without Building Automation System

Air quality (CO2) measurement in air ducts

Used in all common HVAC applications

Used in Commercial and Industrial Buildings

Features

Sensor with active output

Sensor with photoacoustic sensing principle

Can be used 24h / 365d applications such as call center, hospital, etc.

Sensor output 0...10V or 4...20mA, field selectable

Professional and practical product design, withstands rough environmental conditions

Easy to use, install and maintain

Product Range

Order Code	Power Supply	Sensor Output CO2	Immersion Length	Accuracy	IP- Protection
GDI1.HE	AC/DC 24V ($\pm 10\%$)	0...10V or 4...20mA field selectable	150mm	$\pm 40\text{PPM}$ +5% of reading	IP54 according to EN60529, IP65 with bolted cover

Sensor Specification	Sensor Specification	Measured	CO2
		Sensor Characteristics	Active
		Sensor Output	0...10V or 4...20mA
		Accuracy	max. ±40ppm or ±5% of measured value
		Repetability	± 10PPM
		Drift	max. ± 5PPM+ 0.5% of reading
		Response Time (T ₆₃)	60 sec.
		Sensor Element	Photoacoustic CO2 sensor technology
		Measuring Range	0...2000ppm
Technical Information	Electrical Information	Power Supply	AC/DC 24V (±10%)
		Frequency	50 / 60 Hz @ AC 24V
		Output Load	Min. load 10kΩ @ AC/DC 24V
		Measuring Current	<1mA
		Power Consumption	Max. 3.0W
	Mechanical Information	Sensor Pipe Diameter	Ø19.5mm
		Sensor Pipe Length	150mm
		Sensing Element Position	Inside the housing
	User Interface		None
	Color and Material	Housing Cover	PA6, pure white
		Housing Bottom	PA6, pure white
		Cable Gland	PA6, pure white
		Gland Rubber Seal	ENSOF50, RAL9016 (Traffic White)
		Sensor Pipe	PA6, RAL 9017 (Traffic Black)
	Environmental Condition	Operation Temperature	0°C...+50°C
		Operation Humidity	<85% r.h., no condensation
		Transport Temperature	-35°C...+70°C
		Transport Humidity	< 90% r.h.
		Storage Temperature	-20°C...+70°C
		Storage Humidity	< 85% r.h., no condensation
	Norms and Directives	IP- Rating	IP54 according to EN 60529, IP65 with bolted cover
		Safety Class	III to EN 60 730
		Product Standard 1	Automatic Electric. Controls for household and similar use
		Product Standard 2	2009/EN 60 730-1
		CE Conformities	2004/108/EG Electromagnetic Compatibility EMV
		Emitted Interference	2000/EN60730-1 Emitted Interference
		Interference Resistance	2000/EN60730-1 Interference Resistance
		RoHS Compatibility	RoHS 3, Directive 2015/863
		Operation Climatic Condition	IEC 60721-3-3
		Operation Mechanical Condition	IEC 60721-3-2 to class 2M2
		Transport to Climatic Condition	IEC 60721-3-2
		Transport Mechanical Condition	IEC 60721-3-2 to class 2M2
Storage Climatic Condition		IEC 60721-3-1	
Storage Mechanical Condition		IEC 60721-3-1 to class 2M2	
Miscellaneous		Accessories	Mounting Kit, Included in delivery
	Shipping & Handling	Minimum Order	1 box with 1 piece
		Packaging Material	Rigid Cardboard
	Order Notes	Order Code	GDI1.HE

Installation Notes



Observe the following general regulation for engineering and implementation:

- All relevant national and heavy power regulation
- Other country specific regulations
- Country-specific regulations
- Local electrical supply authority regulation
- Schematics, cable listings, dispositions, specification and arrangements from the customer or engineering office in charge
- Third party specifications, e.g. general contractors or constructors

Advices

Mounting Advices

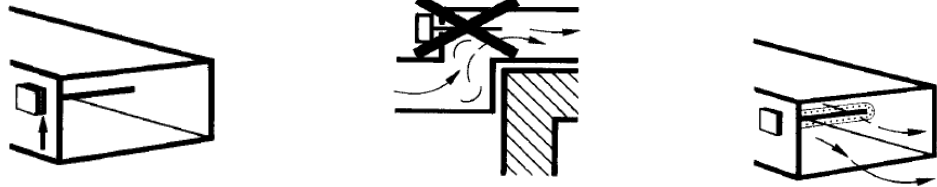

Disposal Notes



The device is considered an electronic device for disposal in terms of the EUROPEAN DIRECTIVE 2012/19/EU.

The device may not be disposed as domestic garbage.

The device must be disposed through channels provided for this purpose.

It is mandatory to complying with local currently applying laws and regulations.

Dimensional Drawing

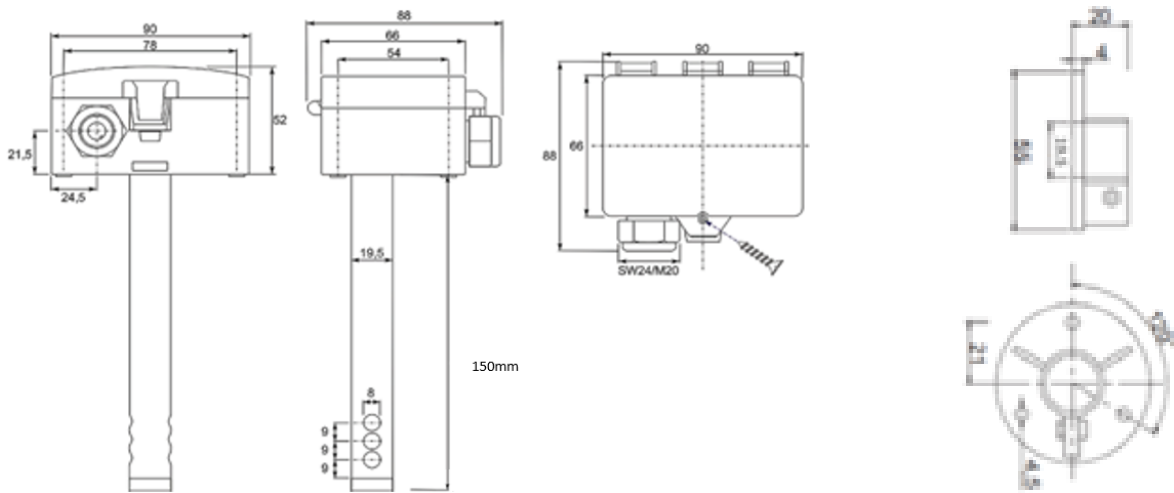

Connection, Settings and Accuracy

Terminals

T1	UB+ (24V AC/DC)
T2	GND
T3	Air Quality (CO2)
T4	n/a
T5	n/a

DIP- Settings

not used	Output Signal (DIP4)
DIP1	DIP4
DIP2	DIP4
DIP3	DIP4
DIP5	DIP4
not used	0...10V
	4...20mA

Accuracy

